

Combat[®]

Compact Tubular Unit Heaters Installation, Commissioning, Operation & Service Manual

Models CTCU 7
CTCU 11
CTCU 15
CTCU 22
CTCU 27
CTCU 32



FOR YOUR SAFETY

If you smell gas:

1. Open windows.
2. **DO NOT** try to light any appliance.
3. **DO NOT** use electrical switches.
4. **DO NOT** use any telephone in your building.
5. Leave the building.
6. Immediately call your local gas supplier after leaving the building. Follow the gas supplier's instructions.
7. If you cannot reach your gas supplier, call the Fire Department.

WARNING



Fire Hazard

Do not store or use petrol or other flammable vapours and liquids in the vicinity of this or any other appliance.

Some objects will catch fire or explode when placed close to heater.

Failure to follow these instructions can result in death, injury or property damage.

WARNING

Improper installation, adjustment, alteration, service or maintenance can result in death, injury or property damage. Read the installation, operation and service manual thoroughly before installing or servicing this equipment.

Installation must be done by a registered installer/contractor qualified in the installation and service of gas-fired heating equipment or your gas supplier.

Installer

Please take the time to read and understand these instructions prior to any installation. Installer must give a copy of this manual to the owner.

Owner

Keep this manual in a safe place in order to provide your serviceman with necessary information.



Quality in Any Language™

© Copyright 2006 Roberts-Gordon, LLC

Roberts-Gordon Europe Limited

Oxford Street
Bilston, West Midlands WV14 7EG UK
Telephone: +44(0) 1902 494425
Fax: +44(0) 1902 403200
Service Telephone: +44(0) 1902 498733
Service Fax: +44(0) 1902 401464
E-mail: uksales@rg-inc.com
E-mail: export@rg-inc.com
www.rg-inc.com



Authorised User No. 00184

P/N 111100UK Rev B 10/06

TABLE OF CONTENTS

SECTION 1: Heater Safety	2	SECTION 13: Conversion Between Gases	21
SECTION 2: Installer Responsibility	2	13.1 General	21
2.1 Clearances to Combustibles	2	13.2 Burner Conversion	21
2.2 Corrosive Chemicals	2	13.3 Gas Valves	21
2.3 National Standards and Applicable Codes	2	SECTION 14: Troubleshooting	22
SECTION 3: Critical Considerations	3	14.1 General	22
3.1 Basic Information	3	14.2 Troubleshooting For Automatic Ignition Burner Systems	23
3.2 Location and Suspension	3	14.3 Troubleshooting for Flame Supervision System	24
3.3 Minimum Required Installation Clearances	3	14.4 Troubleshooting for Solenoid Valves	25
3.4 Clearances to Combustibles	3	14.5 Troubleshooting for Main Fan	25
3.5 Ventilation	3	SECTION 15: Removal and Replacement Parts	26
3.6 Gas Supply	3	15.1 Gas Valve	26
3.7 Electrical Supply	3	15.2 Burner Compartment	27
3.8 Flue	3	15.3 Ignition Electrode and Flame Probe	28
SECTION 4: Specifications	5	15.4 Flue Fan Vertical Installation	29
4.1 CTCUA (All Models)	5	15.5 Pressure Switch	30
4.2 General Technical Data Table (All Models)	6	15.6 Ignition Control	31
4.3 Technical Data Table (All Models)	6	15.7 CTCUA Axial Fan/Guard/Motor Assembly	31
SECTION 5: Heater Installation	7	15.8 Fan and Limit Thermostats	31
5.1 General	7		
5.2 Shelf Mounting and Suspension	7		
5.3 Wall Mounting	7		
SECTION 6: Flue Installation	9		
6.1 Changing Flue and Air Intake Orientation	9		
6.2 Flue Installation	9		
6.3 Type C ₁₂ , C ₃₂ & C ₆₂ Appliance	9		
6.4 Type B ₂₂ Appliance	9		
SECTION 7: Air Supply	11		
7.1 Room Sealed Installation	11		
7.2 Open Flued Installation	11		
7.3 Building Ventilation	11		
SECTION 8: Gas Piping	12		
8.1 Connections	12		
SECTION 9: Wiring and Electrical Information	13		
9.1 Electrical Supply	13		
9.2 Remote Controls	13		
9.3 CTCUA Wiring Diagram Models 7 - 32	14		
SECTION 10: Commissioning	15		
10.1 Pre-Commission Checks	15		
10.2 Begin Commissioning	15		
10.3 Complete the Commissioning	17		
SECTION 11: User Instructions	18		
11.1 User Instructions	18		
11.2 Heater Operation	18		
11.3 Common User Controls	18		
11.4 Lighting Instructions	18		
11.5 Simple Fault Finding	19		
SECTION 12: Servicing	20		
12.1 Servicing Instructions	20		
12.2 Burner Maintenance	20		
12.3 Fan/Motor Assembly Maintenance	20		
12.4 Heat Exchanger Maintenance	20		
12.5 Gas Control Valve Maintenance	20		
12.6 Flue Fan	20		

© 2006 Roberts-Gordon, LLC

All rights reserved. No part of this work covered by the copyrights herein may be reproduced or copied in any form or by any means - graphic, electronic, or mechanical, including photocopying, recording, taping or information storage and retrieval systems - without the written permission of Roberts-Gordon, LLC.

Printed in U.S.A.

TABLE OF FIGURES

Figure 1: Installation Clearances and Clearances to Combustibles.....	4
Figure 2: Suspension Methods	7
Figure 3: Shelf Mounting and Hanging Suspension.....	8
Figure 4: Vertical Louvres (Optional)	8
Figure 5: Flue and Roof Detail	9
Figure 6: Vertical and Horizontal Flue Termination - Type B ₂₂ Appliance	10
Figure 7: Vertical and Horizontal Flue Termination - Type C ₁₂ C ₃₂ & C ₆₂ Appliances.....	10
Figure 8: Gas Connection with Stainless Steel Flex Connector	12
Figure 9: Automatic Burner Control Box Sequence	16
Figure 10: Gas Valve for Heater Models 7 - 32	16
Figure 11: Heater Operating Sequence.....	18





Authorised User No. 00184

COMBAT® Compact Tubular Unit Heaters are high efficiency heaters and are listed on the Enhanced Capital Allowance Scheme 'Energy Technology Product List'. The ETL symbol is a UK registered certification mark of The Carbon Trust.

Product Approval

ROBERTS GORDON® appliances have been tested and CE certified as complying with the essential requirements of the Gas Appliance Directive, the Low Voltage Directive, the Electromagnetic Compatibility Directive and the Machinery Directive for use on natural gas and LPG when installed, commissioned and maintained in accordance with these instructions.

These instructions refer to appliances designed to operate in the European Union.

Appliances designed for other countries (non European Union) are available on request.

This appliance must be installed in accordance with the local and national codes in force and used only in a sufficiently ventilated space, as specified in these instructions.

Before installation, check that the local gas distribution systems, nature of gas and pressure, and adjustment of the appliance are compatible.

SECTION 1: HEATER SAFETY



Your Safety is Important to Us!
This symbol is used throughout the manual to notify you of possible fire, electrical or burn hazards. Please pay special attention when reading and following the warnings in these sections.

Installation, service and annual inspection of heater must be done by a registered installer/contractor qualified in the installation and service of gas-fired heating equipment.

Read this manual carefully before installation, operation, or service of this equipment.

This heater is designed for heating non-residential indoor spaces. Do not install in residential spaces. These instructions, the layout drawing, local codes and ordinances and applicable standards that apply to gas piping, electrical wiring, venting, etc. must be thoroughly understood before proceeding with the installation.

SECTION 2: INSTALLER RESPONSIBILITY

- To install the heater, as well as the gas and electrical supplies, in accordance with applicable specifications and codes. Roberts-Gordon recommends the installer contact a local building inspector, Fire Officer or insurance company for guidance.
- To use the information given in the manual together with the local and national codes to perform the installation.
- To install the heater in accordance with the clearances to combustibles of this heater.
- To furnish all needed materials not furnished as standard equipment.
- To plan location of supports, flues and air intakes.
- To provide access to burners for servicing.
- To provide the owner with a copy of this Installation, Commissioning, Operation and Service Manual.
- To never use heater as support for ladder or other access equipment and never hang or suspend anything from heater.
- To ensure that there is sufficient ventilation in the area to comply with the requirements of all relevant local and national codes.

2.1 Clearances to Combustibles

In all situations, clearances to combustibles must be maintained. Caution must be used when running the heater near combustible materials such as wood, paper, rubber, etc. A wall tag is on the back cover of this manual as a permanent reminder of the safety instructions and the importance of the required

clearances to combustibles. Affix the tag on a wall near the heater.

2.2 Corrosive Chemicals

CAUTION

Do not use heater in an area containing corrosive chemicals.

Corrosive chemicals will damage the burner and heat exchanger parts.

Failure to follow these instructions can result in property damage.

Roberts-Gordon cannot be responsible for ensuring that all appropriate safety measures are undertaken prior to installation; this is entirely the responsibility of the installer. It is essential that the contractor, the sub-contractor, or the owner identifies the presence of combustible materials, corrosive chemicals or halogenated hydrocarbons* anywhere in the premises.

* **Halogenated Hydrocarbons** are a family of chemical compounds characterized by the presence of halogen elements (fluorine, chlorine, bromine, etc.). These compounds are frequently used in refrigerants, cleaning agents, solvents, etc. If these compounds enter the air supply of the burner, the lifespan of the heater components will be greatly reduced. Warranty will be invalid if the heater is exposed to halogenated hydrocarbons.

2.3 National Standards and Applicable Codes

All appliances must be installed in accordance with the latest revision of applicable standards and local and national codes. This refers also to the electric, gas and venting installation. Note: Additional standards for installations in public garages, aircraft hangars, etc. may be applicable.

SECTION 3: CRITICAL CONSIDERATIONS

3.1 Basic Information

CTCU heaters have automatic ignition burners for ON/OFF operation only.

3.2 Location and Suspension

All models:

- Must be installed indoors.
- Must be installed in a level position with horizontal or vertical discharge.
- May be mounted on a shelf of non-combustible material. (See Page 5, Section 4 and Page 7, Figure 2 for support points.)
- May be suspended from above (See Page 7, Figure 2) or from wall brackets of sufficient strength to support the heater as listed in the Dimension Data Table on Page 5, Section 4.1. Drop rods must be a minimum of 10 mm diameter mild steel. Four suspension points (M10 nuts) are located on top and back side of the heater.
- Must be installed in a manner which allows access to all serviceable components.

3.3 Minimum Required Installation Clearances

Clearances around the heater and flue must be as indicated on Page 4, Figure 1; Page 9, Figure 5 through Page 10, Figure 7 to ensure access for servicing, and correct operation.

3.4 Clearances to Combustibles

Clearances must be as indicated on Page 4, Figure 1. If clearances to combustibles are not indicated, then installation clearances apply.

3.5 Ventilation

It is important to ensure that there is adequate air circulation around the heater to supply air for combustion, ventilation and distribution in accordance with local and national codes.

3.6 Gas Supply

It is important that the gas supply pipe is sized correctly to provide the inlet pressure as stated on the heater data plate. The gas supply pipe and electrical connections must not support any of the heater's weight.

3.7 Electrical Supply

A permanent 230 V 50 Hz 1 Ø electrical supply is required at the main electrical terminals. The heater also requires suitable energy controls in accordance with Section 9.

3.8 Flue

Choose heater siting to allow for the proper location of the flue. Each heater must be fitted with an individual and correctly sized sealed flue system (See Page 9, Section 6).

No other appliance may be connected to the flue.

For room sealed installation, the air intake must be the same size sealed system and the flue/air intake must terminate at an approved concentric wall or roof terminal.

⚠ WARNING



Fire Hazard

Some objects will catch fire or explode when placed close to heater.

Keep all flammable objects, liquids and vapours the required distance away from the heater.

Failure to follow these instructions can result in death, injury or property damage.

Figure 1: Installation Clearances and Clearances to Combustibles

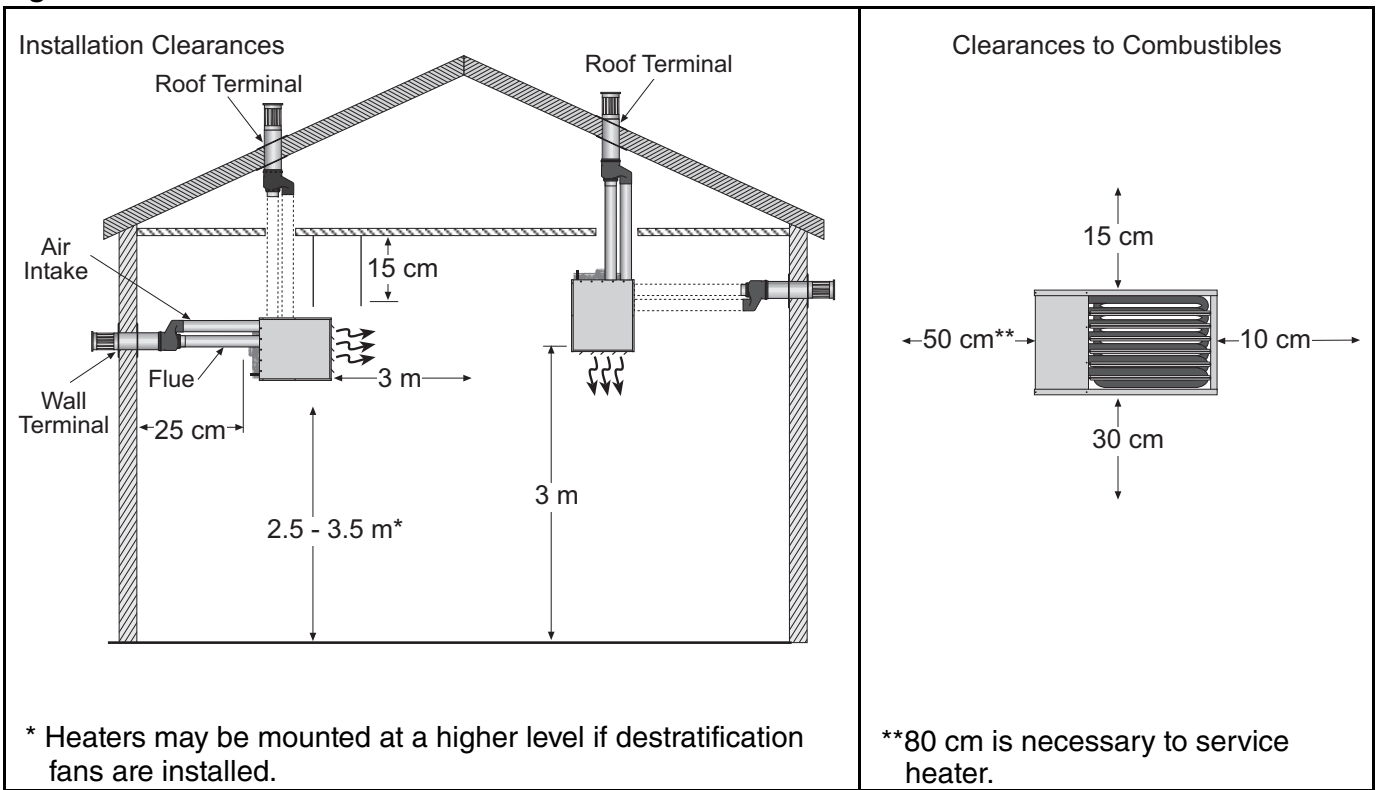

The heater must always be installed at least 1.8 m above the floor.
The flue pipe must have clearance from combustibles by 5 cm.

If installed at low levels where individuals can come in contact with hot heat exchanger components, adequate guarding must be provided.

All distances are minimum clearance requirements for service access, air flow and safety.

SECTION 4: SPECIFICATIONS

4.1 CTCUA (All Models)

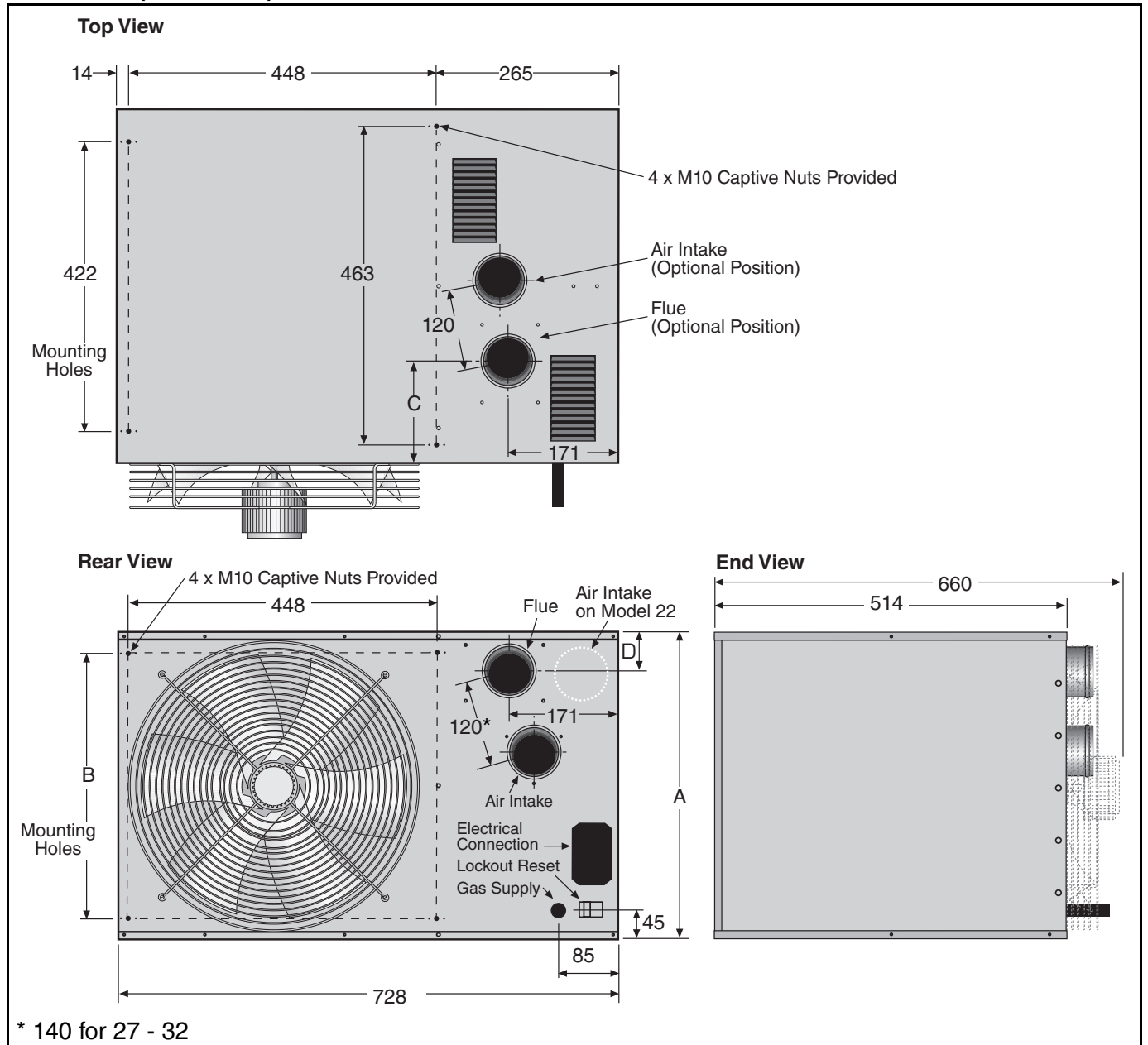

Dimension Data - CTCUA (All Models)

		Model	CTCU-7	CTCU-11	CTCU-15	CTCU-22	CTCU-27 / 32
A	Height	mm (in)	304 (12.0)	304 (12.0)	450 (17.7)	450 (17.7)	578 (22.8)
B	Mounting Hole Spacing	mm (in)	239 (9.4)	239 (9.4)	385 (15.2)	385 (15.2)	513 (20.2)
C	Centre of Flue (Top Option)	mm (in)	151 (5.9)	151 (5.9)	151 (5.9)	172 (6.8)	149 (5.9)
D	Centre of Flue	mm (in)	68 (2.7)	68 (2.7)	68 (2.7)	46 (1.8)	59 (2.3)
	Weight	kg	28	30.5	38.5	41	52.3

4.2 General Technical Data Table (All Models)

	Model	CTCU-7	CTCU-11	CTCU-15	CTCU-22	CTCU-27 / 32
CTCUA, Axial Fans						
Total Electrical Load	W	260	274	336	384	345
Run Current	A	1.1	1.2	1.5	1.7	1.5
Start Current	A	1.7	1.8	2.5	2.9	2.6
Air Flow	m ³ /h	1120	1220	2710	2750	4474
Sound Pressure Level at 3 m	[NR] dB(A)	[31] 37	[35] 41	[39] 45	[42] 48	[42] 48
Flue and Air Intake						
Flue and Air Intake Size	mm Ø	80	80	80	80	100
*Maximum Straight Flue/Air Intake	m	2.5	4	5	5	5

Electrical load at 230 V 50 Hz measured by calculating from total run current of appliance.

* Do not exceed the maximum length of flue stated or heater may not operate properly.

Reduce the maximum length stated by 1 m for each 90° bend installed.

**If minimum air flow requirements are not met, then temperature limit devices will shut down the heater.

4.3 Technical Data Table (All Models)

Appliance Category II _{2H/L 3B/P}

	Model	CTCU-7	CTCU-11	CTCU-15	CTCU-22	CTCU-27	CTCU-32
Heat Input Gross CV	kW (Btu/h) x (1000)	8.5 29	13.4 46	18.3 62	27.5 94	33 113	38.5 131
Heat Input Net CV	kW (Btu/h) x (1000)	7.7 26	12.1 41	16.5 56	24.8 85	29.7 101	34.7 118
Approximate Heat Output	kW (Btu/h) x (1000)	7.1 24	11.1 38	15.1 52	23 78	27.2 93	31.7 108
Natural Gas (G20) Data - Inlet Pressure 20 mbar (7.8 in WG) Min. 17 mbar (6.8 in WG) Max. 25 mbar (10 in WG)							
Burner Pressure	mbar	9.5	9.5	9.5	9.5	9.0	9.0
Gas Rate	m ³ /h ft ³ /h	0.8 29	1.3 45	1.7 62	2.6 93	3.1 110	3.6 127
Natural Gas (G25) Data - Inlet Pressure 25 mbar (10 in WG) Min. 20 mbar (7.8 in WG) Max. 30 mbar (12 in WG)							
Burner Pressure	mbar	9.0	9.0	9.5	9.2	9.2	9.3
Gas Rate	m ³ /h ft ³ /h	0.9 33	1.5 52	2.0 72	3 108	3.6 127	4.2 148
LPG / Propane (G31) Data - Inlet Pressure 37 mbar (14.6 WG) Min. 25 mbar (10 in WG) Max. 45 mbar (18 in WG) Alternative where permitted 50 mbar (20 in WG) Min. 42.5 bar (17 in WG) Max. 57.5 mbar (23 in WG)							
Burner Pressure	mbar	25.6	29.4	29.4	28.6	29.9	29.9
Gas Rate	m ³ /h kg ³ /h	0.3 0.16	0.5 0.25	0.7 0.34	1 0.51	1.2 .61	1.4 .71
LPG / Butane (G30) Data - Inlet Pressure 29 mbar (11,4 in WG) Min. 20 mbar (7.8 in WG) Max. 35 mbar (13.8 WG)							
Burner Pressure	mbar	19.2	21.9	22.9	21.4	21.4	22.4
Gas Rate	m ³ /h kg ³ /h	0.2 0.09	0.4 0.14	0.5 0.19	0.8 0.29	.9 .34	1.1 .42

Gas rates corrected to standard conditions 1013.25 mbar 15° C.

SECTION 5: HEATER INSTALLATION

5.1 General

Heaters are designed for installation above 1.8 m. These heaters must be installed within the heated space. Duct delivery systems are not permitted with axial fans. When handling or supporting the heater from below, ensure that the weight is taken at the support points.

5.2 Shelf Mounting and Suspension

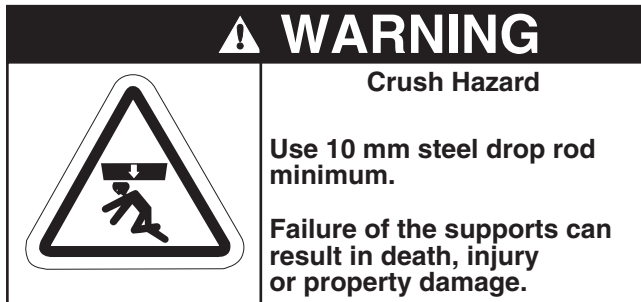

For typical suspension, See Page 7, Figure 2.

Figure 2: Suspension Methods

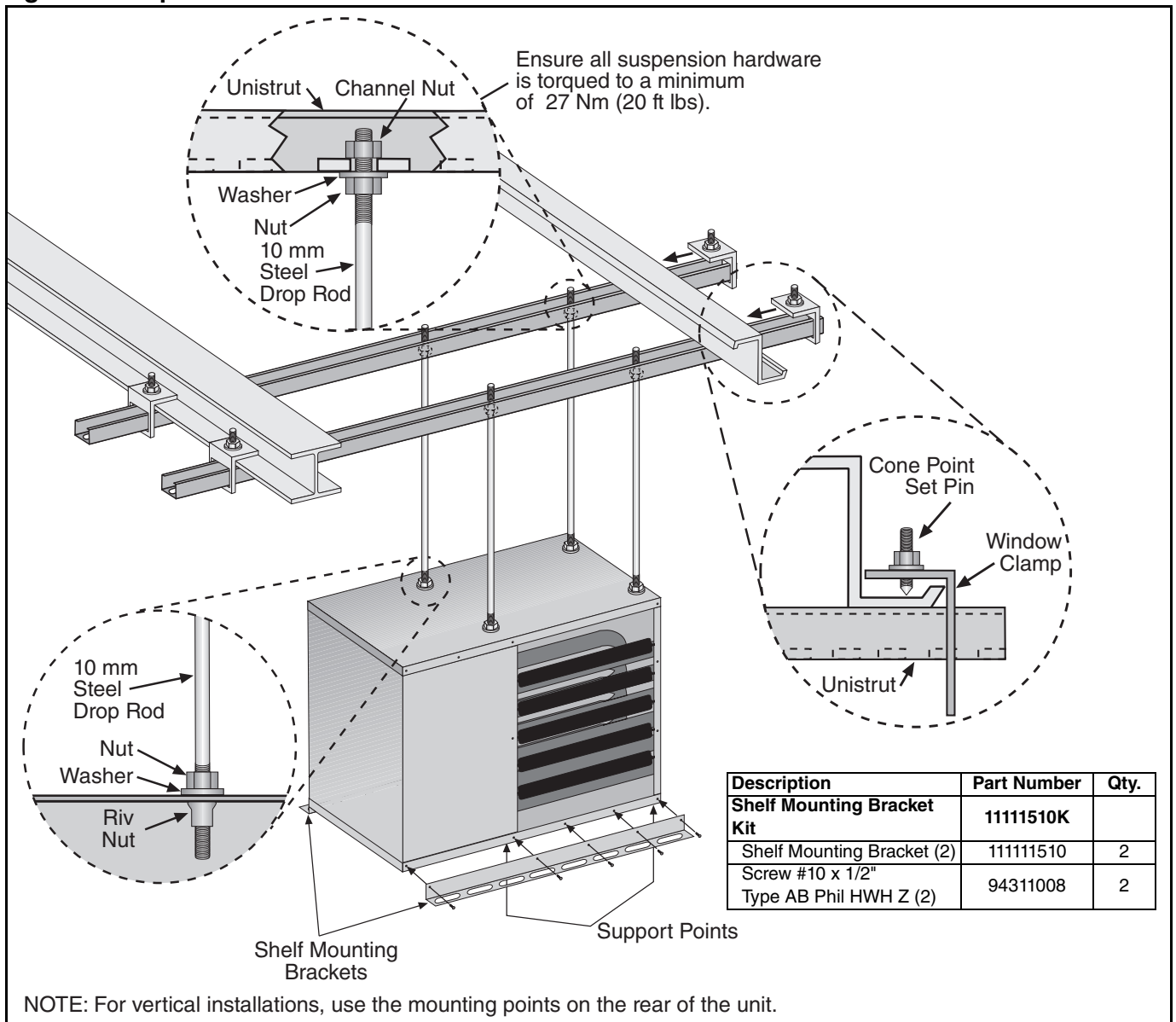

Existing cabinet screws must be re-used.

5.3 Wall Mounting

For typical suspension, See Page 8, Figure 3. Heaters blowing parallel to the wall can only be installed with the service door away from the wall.

The wall mounting brackets must be attached to a suitable wall through all mounting holes. Screw sizes less than M10 may not be used. In order for the wall mounting brackets to adequately carry the weight of the heater, it must be installed with best building practice.

Figure 3: Shelf Mounting and Hanging Suspension

Description	Part Number	Qty.
Wall Shelf Mounting Bracket Kit	11111512K	1
Wall Suspension Mounting Bracket Kit	1111510K	1
Shelf Mounting Bracket Kit	11111511K	1

Description	Part Number	Qty.
Wall Suspension Mounting Bracket Kit	11111511K	1
Wall Mounting Bracket Arm Left	111WALL1L	1
Wall Mounting Bracket Arm Right	111WALL1R	1
Wall Mounting Bracket Vertical	111WAL2	2
Wall Mounting Bracket Diagonal	111WAL3	2
M8 x 85 mm Hex Head Bolt	97311405	6
M8 Lock Nut with Nylon Insert	92204504	6
M8 Flat Washer	95204502	6
M8 Lockwasher	96404502	6

Hardware provided to construct mounting bracket assembly only.

Figure 4: Vertical Louvres (Optional)

Description	Part Number
Vertical Louvre Kit CTCU 7 and 11	11111901K
Vertical Louvre Bracket	11111903
#10 Screw	S103
CTCU 7-11 Vertical Louvres	11111901
Louver Spring	90901200
Instruction Sheet	91040021

Description	Part Number
Vertical Louvre Kit CTCU 15 and 22	11111900K
Vertical Louvre Bracket	11111903
#10 Screw	S103
Instruction Sheet	91040021

Description	Part Number
Vertical Louvre Kit CTCU 27 and 32	11111902K
Vertical Louvre Bracket	11111903
#10 Screw	S103
27-32 Vertical Louvre	11111902
Instruction Sheet	91040021

For models 15 and 22, horizontal louvres are re-used.

SECTION 6: FLUE INSTALLATION

6.1 Changing Flue and Air Intake Orientation

The heater is sold with horizontal flue and fresh air connections as standard. If vertical flue and fresh air connections are required, follow the instructions on Page 29, Section 15.4.

6.2 Flue Installation

⚠ WARNING

Fire Hazard
Some objects will catch fire or explode when placed close to heater.
Keep all flammable objects, liquids and vapours the required distance away from the heater.
Failure to follow these instructions can result in death, injury or property damage.

The flue must terminate outside of the building. Flues and air intakes must be a fully sealed system and correctly sized for the model. Flues should be assembled as detailed on Page 9, Figure 5 through Page 10, Figure 7. The joints between the flue terminal and the roof or wall must be properly sealed. If the flue passes through a wall or ceiling of combustible material it must be enclosed by a sleeve of non-combustible material and be separated from the sleeve by at least a 25 mm air gap.

Flues and air intakes must be adequately supported so that the heater does not bear the weight of the pipes.

For flue termination See Page 9, Figure 5 through Page 10, Figure 7.

6.3 Type C₁₂, C₃₂ & C₆₂ Appliance

Room Sealed.

The heaters are designed to be installed as room sealed appliances. The flue and air intake are run as separate pipes to the special concentric wall or roof terminal. See Page 10, Figure 7. The wire mesh inside the fresh air adapter on the heater must be removed prior to installation.

6.4 Type B₂₂ Appliance

The flue must be fitted with a low resistance terminal. See Page 9, Figure 5 through Page 10, Figure 6.

Figure 5: Flue and Roof Detail

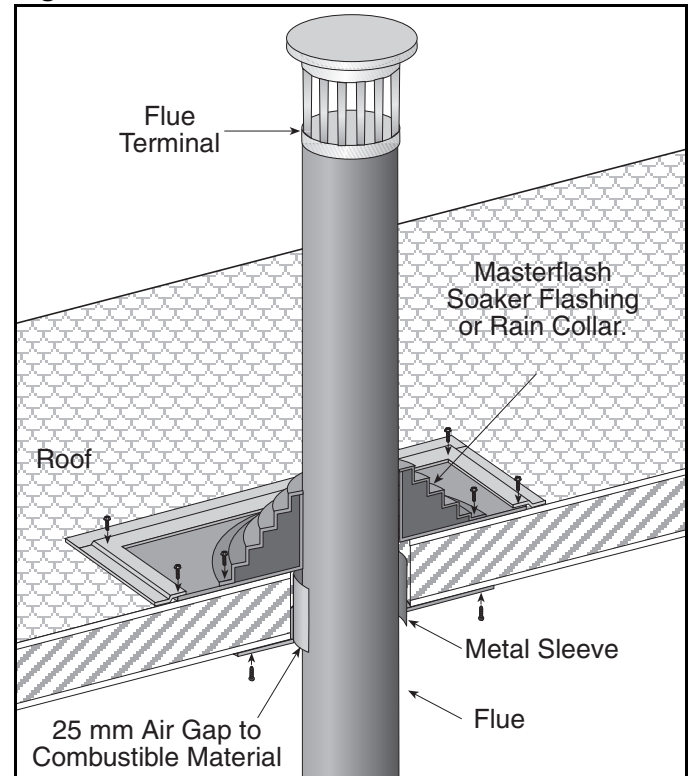

Figure 6: Vertical and Horizontal Flue Termination - Type B₂₂ Appliance

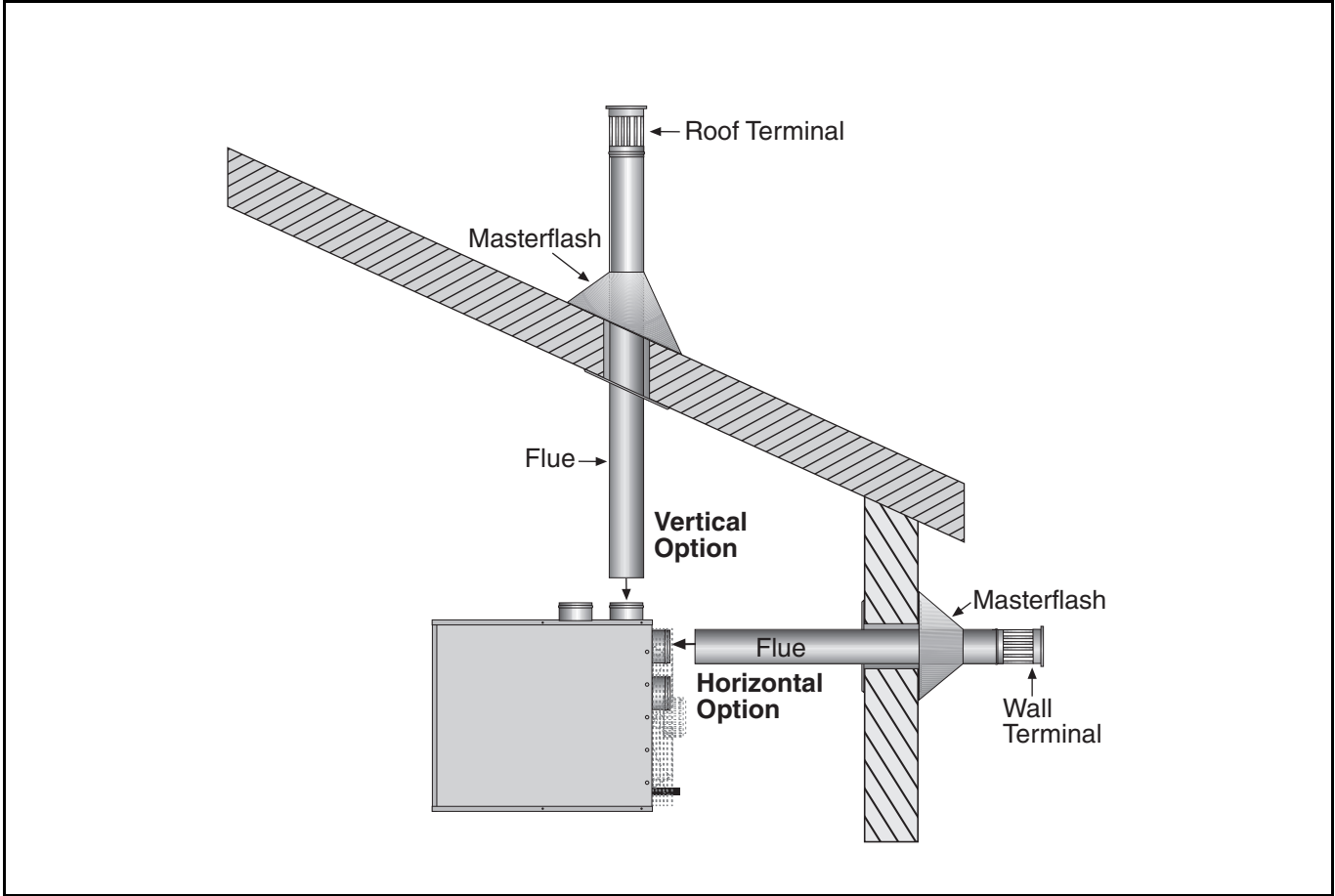
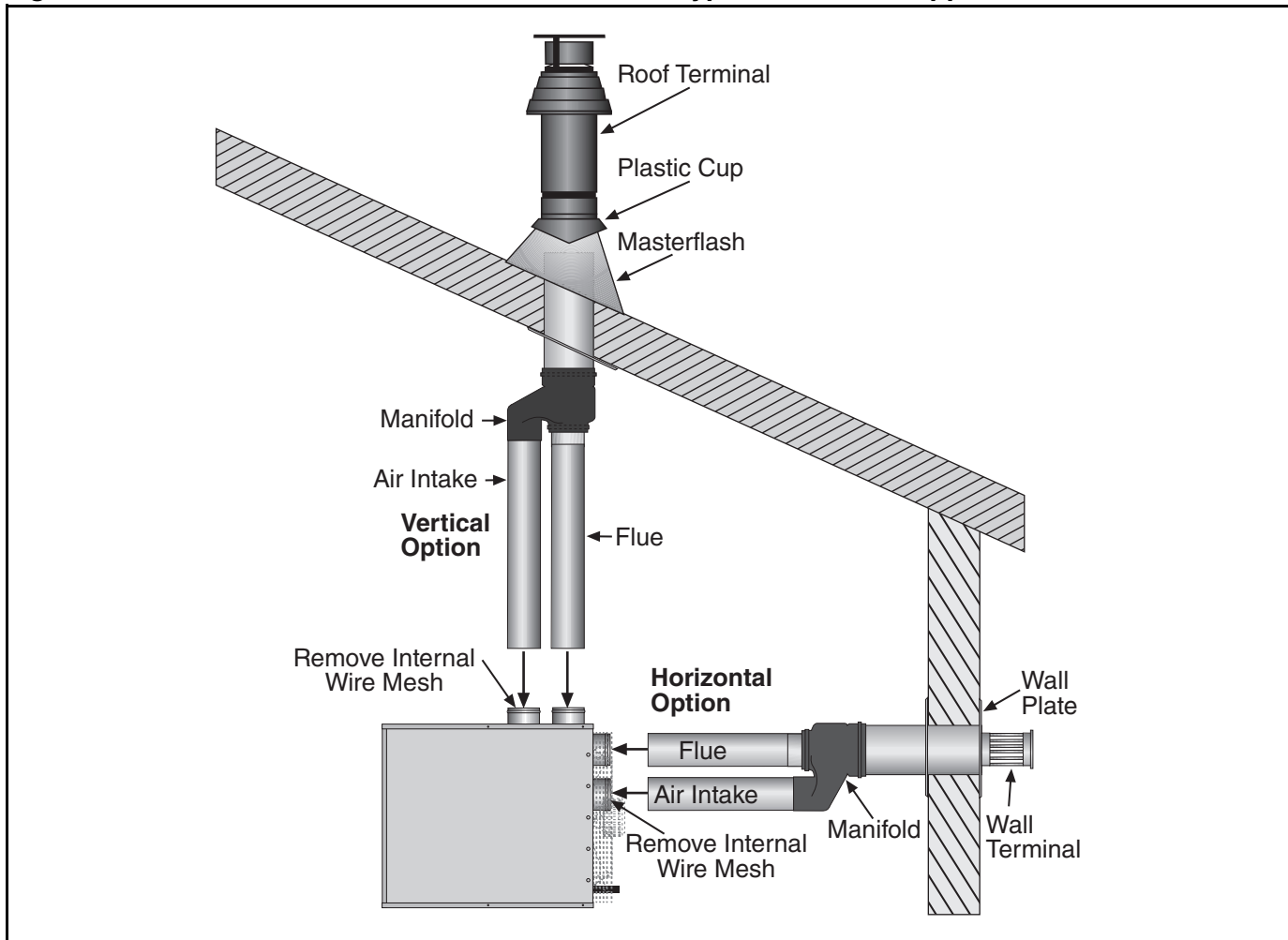

Figure 7: Vertical and Horizontal Flue Termination - Type C₁₂ C₃₂ & C₆₂ Appliances



SECTION 7: AIR SUPPLY

7.1 Room Sealed Installation

When installed as a room sealed heater, the air for combustion is drawn in from outside the building. It is important to ensure that there is adequate ventilation to provide air for the distribution fan.

7.2 Open Flued Installation

It is important to ensure that there is adequate air supply at all times for both combustion and heating requirements in accordance with local and national codes.

7.2.1 Heaters Installed Within the Heated Space

Where the volume of the heated space is greater than 4.7 m³ per kilowatt of total rated heat input and the air change rate is at least 0.5/h, additional high and low level ventilation will not be required.

For a building having an air change rate less than 0.5/h, ventilation will be necessary in accordance with local and national codes. Ventilation direct to outside must be provided as follows:

- Heaters up to 70 kW heat input 5.0 cm² per kW of rated heat input

7.3 Building Ventilation

Where ventilation is required, air must be taken from an outside point where it is not likely to be contaminated or obstructed.

Where natural ventilation is used, suitable ventilation with outside air at low level must be provided in accordance with *Section 7.2.1* and local and national codes.

Where mechanical ventilation is used, extract rate must be 5% - 10% less than the inlet rate. The mechanical ventilation must be interlocked with the burner on the CTCU heater.

SECTION 8: GAS PIPING

⚠ WARNING



Fire Hazard

Connect gas supply according to Figure 8.

Gas can leak if not installed properly.

Failure to follow these instructions can result in death, injury or property damage.

It is important that the gas supply pipe and the electrical connections do not support any of the heater's weight.

A gas meter is connected to the service pipe by the gas supply company. An existing meter should be checked, preferably by the company, to ensure that the meter is adequate for the rate of gas supply required.

Installation pipes must be fitted in accordance with local and national codes. Pipe work from the meter to the heater(s) must be of adequate size. Pipes of smaller size than the heater inlet gas connection should not be used.

8.1 Connections

Connect the heater to the gas supply ensuring that the final connections are as follows:

- Gas supply pipe work is run in medium or heavy gauge tubing in compliance with local and national codes.
- The gas supply pipe is adequately sized to carry the total volume of gas for the complete installation.
- An isolating valve and union connection should be used and fitted into the supply adjacent to the heater.
- For suspended heaters, use an approved metal flexible connection between the isolating valve and the heater. **To reduce pressure loss, use one pipe size larger than the heater gas connection.**

IMPORTANT - The complete installation must be purged and tested for gas soundness in accordance with local and national codes.

Figure 8: Gas Connection with Stainless Steel Flex Connector

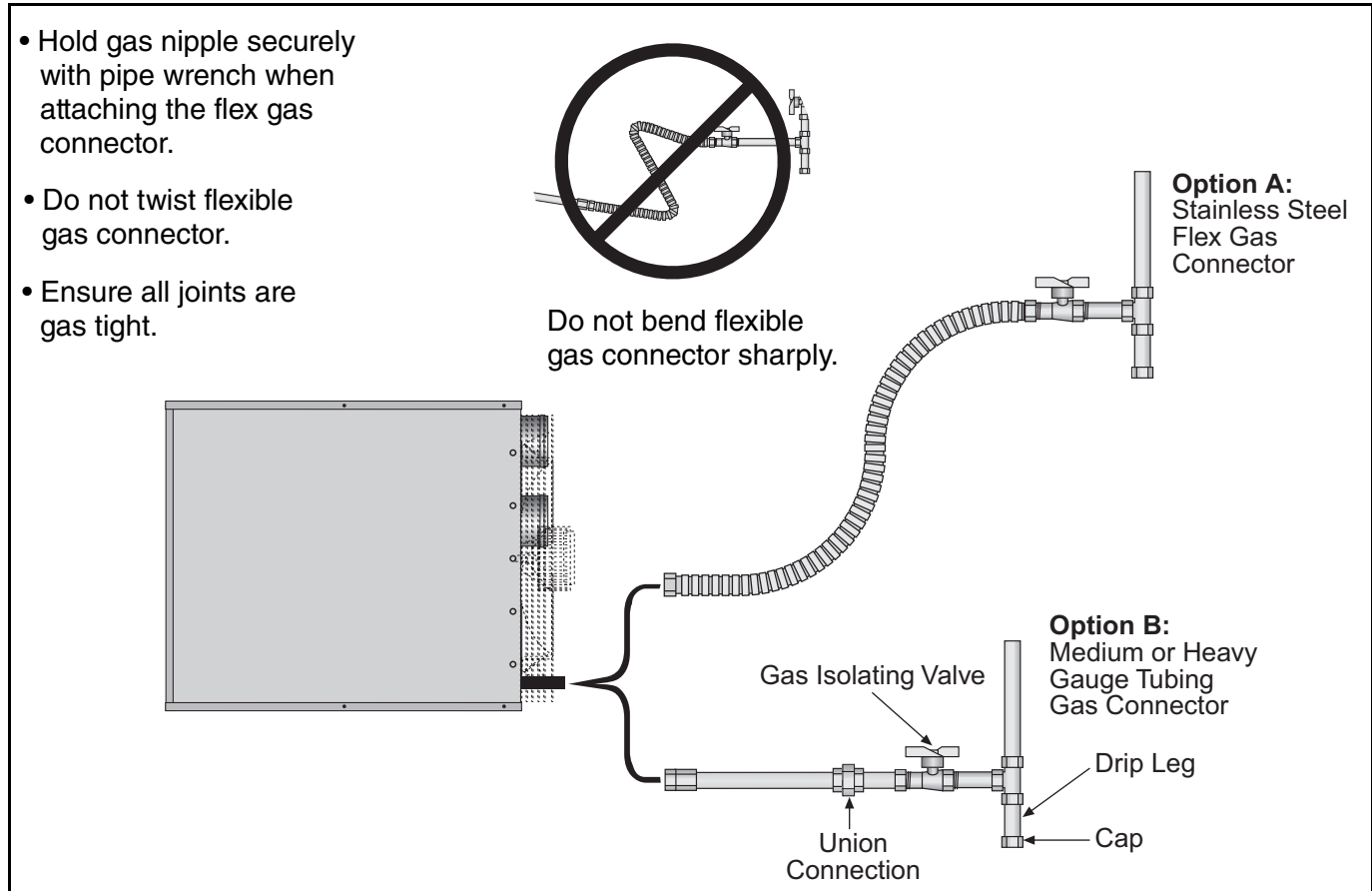

SECTION 9: WIRING AND ELECTRICAL INFORMATION

9.1 Electrical Supply

All heater models need a constant 230 V 50 Hz 1 \emptyset supply connected to terminals L₁, N & Earth.

Polarity "L & N" must be correct. The voltage between neutral and earth should be 0 and never exceed 15 volts.

All heaters and controls must be correctly earthed.

All external wiring must comply with the relevant local codes. Wire specification H05VV-F.

External controls must have the same constant 230 V 50 Hz supply.

An isolator with a contact separation of at least 3 mm on all poles must be installed adjacent to, but not attached to, the heater to disconnect all supplies to the heater and any remote control. This switch should be fused to 5 A.

The final connection to the heater should be made by flexible cable or conduit to the 7 pole plug using 1 mm² cable on all models.

9.2.3 Remote Frost Thermostat

When required, connect to L₁ and T₂ parallel to the room thermostat. Locate within the heated space adjacent to the most vulnerable equipment that requires protection. See *Page 14, Section 9.3*.

9.2.4 Remote Fan Controls

The fan will operate automatically providing there is a constant 230 V supply.

A switch or control wired between L₁ and T₁ will allow external control of the fan(s).

The fan may be controlled to operate continuously from an external control, with the burner cycling on and off, providing that the fan run-on at close down is not impaired.

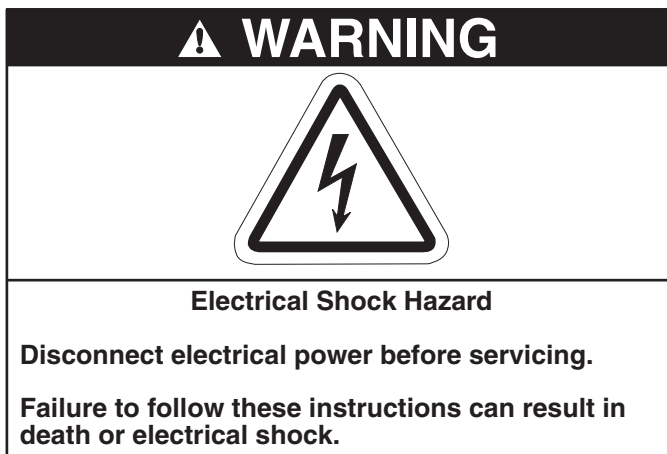

9.2 Remote Controls

The heater is designed to be operated by controls installed remote from the heater. See *Page 14, Section 9.3*.

9.2.1 Burner Controls (Thermostat)

Controls to operate the burner must be connected between L₁ and T₂.

9.2.2 Positioning Room Thermostats or ROBERTS GORDON® Control

A room thermostat or ROBERTS GORDON® control should be mounted on a wall or column at a height of approximately 1.5 metres from the floor to measure the ambient temperature. It should be clear of both cold draughts and the direct path of warm air from the heater.

9.3 CTCUA Wiring Diagram Models 7 - 32

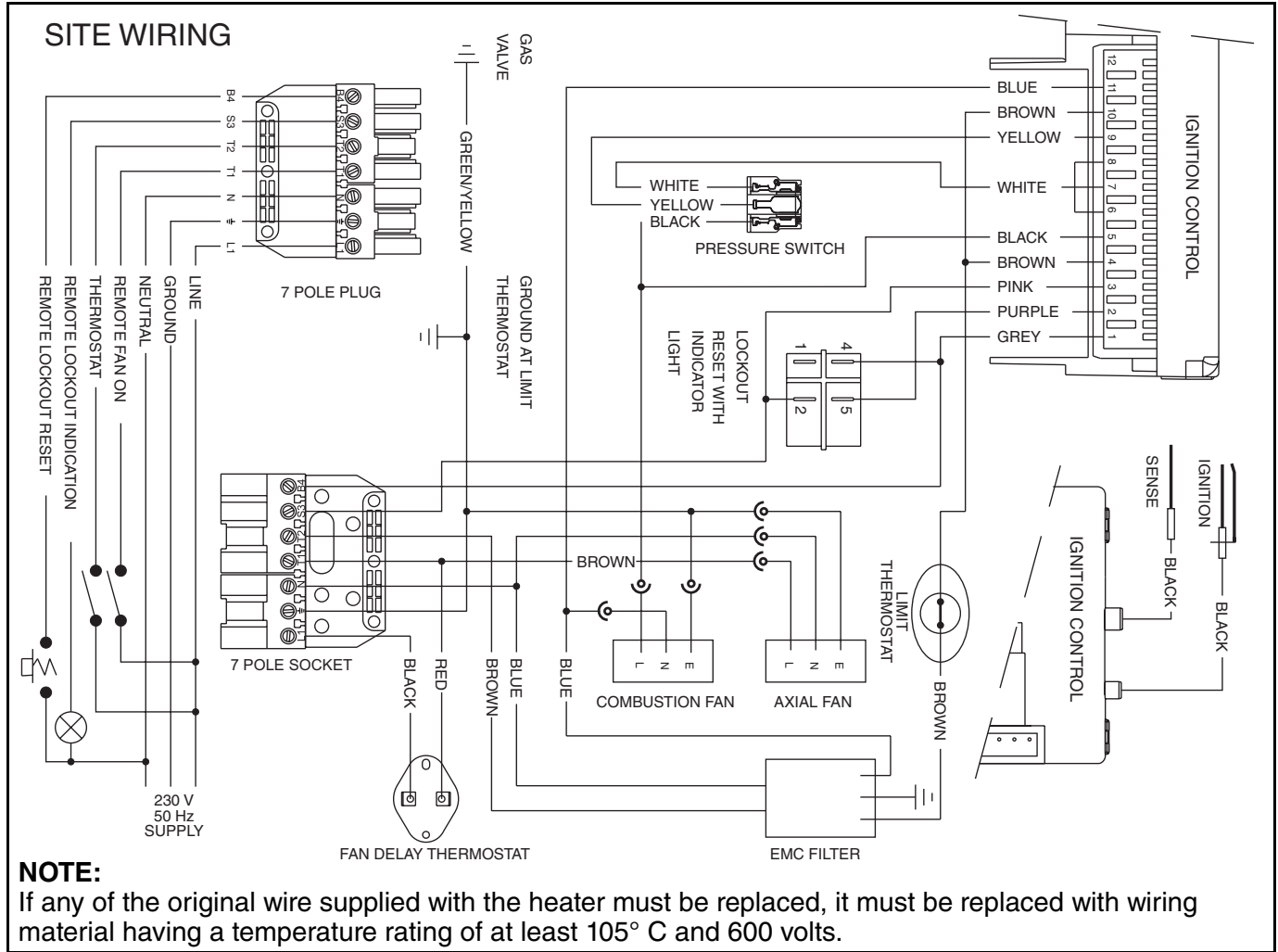

SECTION 10: COMMISSIONING

Installation, service, commissioning and annual inspection of the heater must be done by a contractor qualified in the installation and service of gas-fired heating equipment. Read this manual carefully before installation, commissioning, operation, or service of this equipment. All components are accessed via the door secured by 4 sheet metal screws. Opening the door exposes live electrical connections and hot components.

⚠ WARNING

Electrical Shock Hazard
Use extreme caution while commissioning.
Failure to follow these instructions can result in death or electrical shock.

10.1 Pre-Commission Checks

All pre-commission checks must be carried out before lighting the heater.

Ensure that the heater and all controls are suitable for the gas, pressure and electrical supply to which they are to be connected.

10.1.1 Louvres

Where fitted, the air delivery louvres need to be set during commissioning to give the required air distribution (optional vertical louvres).

⚠ WARNING

Cut Hazard
Turn off gas and electrical supply before maintenance.
Fan can start automatically at any time.
Failure to follow these instructions can result in severe injury or product damage.

10.1.2 Electrical Checks

All pre-commission checks must be carried out before commissioning the heater.

1. Check that all site wiring is connected in accordance with the appropriate wiring diagram on Page 14, Section 9.3.
2. Check the correct fuse size is fitted; See Page 13, Section 9.1.

10.1.3 Gas Supply

All aspects of the gas installation including the gas meter must be inspected, tested for soundness and purged in accordance with local and national codes. Ensure that the air is fully purged from the heater inlet pipe up to the main gas valve inlet test nipple.

10.1.4 Mechanical Checks

1. Check that the fan is free to run and delivery louvres are turned to give required air deflection.
2. Check that the flue (and air intake for room sealed) is installed in accordance with these instructions and local regulations.

NOTE: The limit thermostat is sealed at the factory and is not adjustable.

10.2 Begin Commissioning

10.2.1 Before Operating the Heater

To ensure that all the controls are in safe working order, operate the heater for the first time with the isolating gas valve turned off.

1. Turn off the isolating gas valve.
2. Using the installed external control, turn on the burner. The automatic sequence will now begin as described on Page 16, Figure 9.

There will be no ignition of the burner and lockout will occur, which proves the controls are operating correctly.

Figure 9: Automatic Burner Control Box Sequence

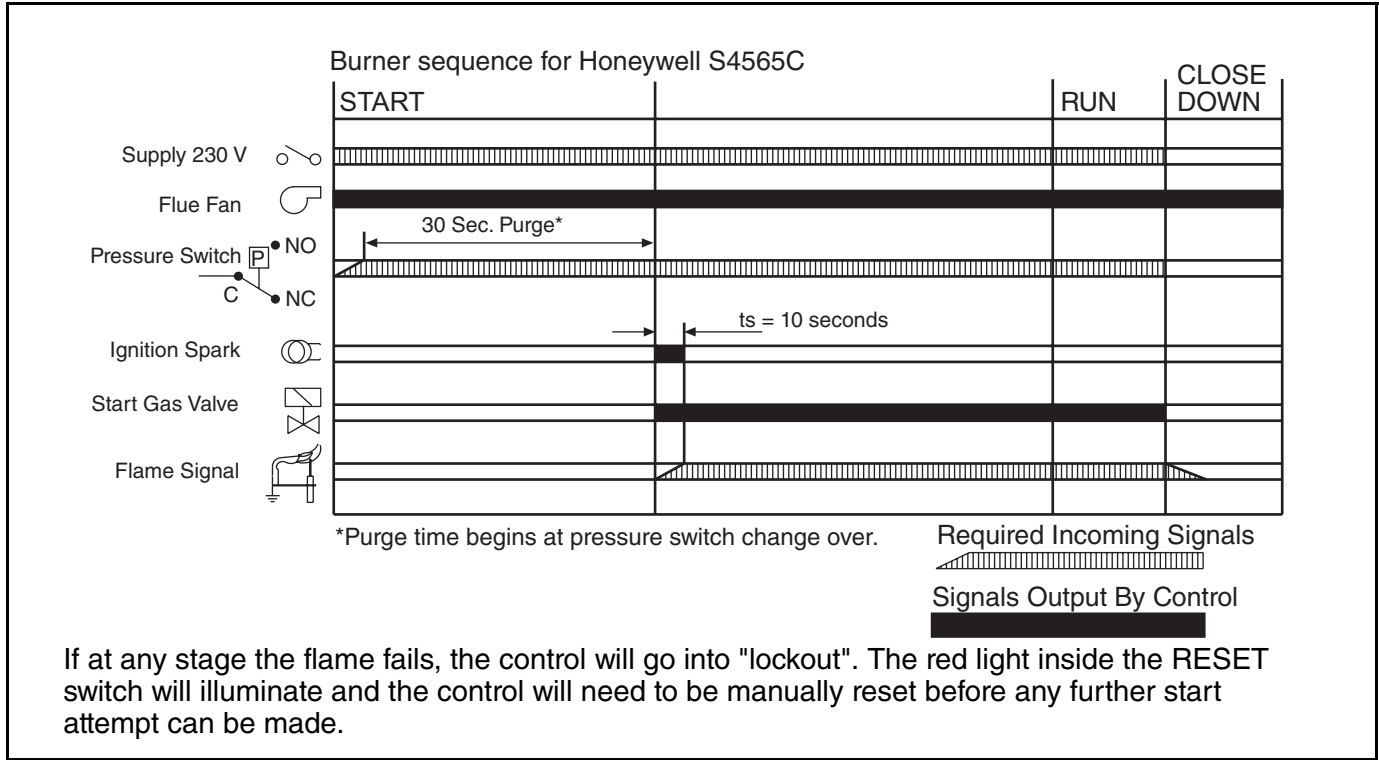
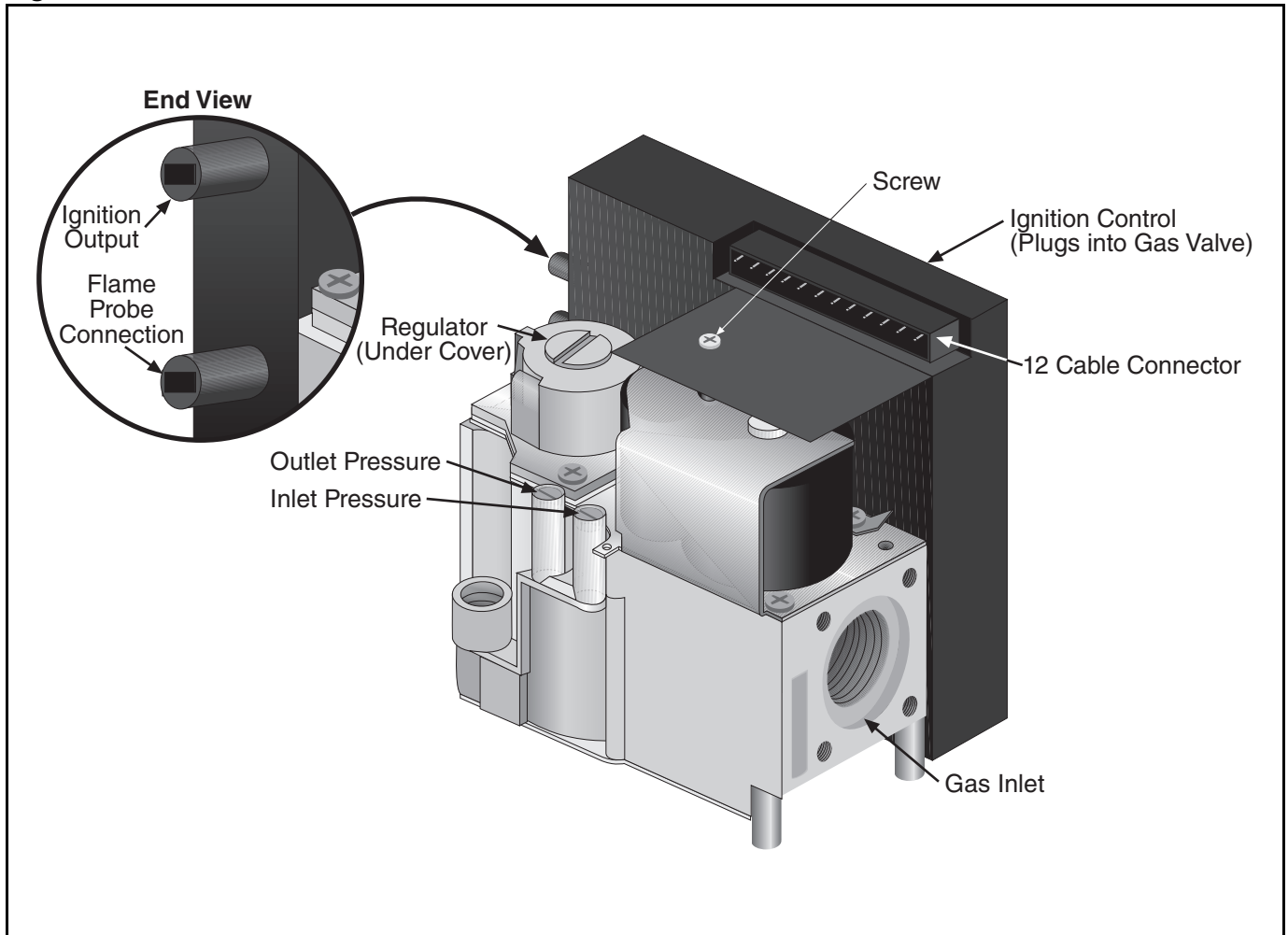

Figure 10: Gas Valve for Heater Models 7 - 32



10.2.2 Commissioning the Gas Valve (All Gases)

10.2.2.1 Check Burner Gas Pressure

1. Loosen the screw cover of the outlet (burner) pressure test point and connect a manometer.
2. With the burner firing, measure the pressure on the manometer. To adjust the burner pressure, remove the regulator cover from the valve and turn the regulator adjustment screw to set the required burner pressure as stated in the Technical Data Tables for the correct gas and model on Page 6, Section 4.3.

NOTE: If the correct burner pressure cannot be reached, then check the inlet pressure to the valve, with the burner firing. See Technical Data Tables on Page 6, Section 4.3 for inlet pressure requirement.

Do not continue to adjust the regulator if the pressure is not changing.

If the inlet pressure is too low to allow correct burner pressure setting, then the gas inlet pressure must be corrected before completing the commissioning.

Check Gas Rate

1. After burner pressure adjustment, allow the heater to operate for at least 15 minutes and then re-check settings.
2. Remove the manometer and refit all covers to the valve and tighten the screw of the outlet pressure tap.
3. Check gas flow rate at gas meter.

10.2.3 Combustion Testing

The only adjustment to alter combustion performance is burner pressure. Combustion quality must be tested to prove correct heater operation. Incorrect results will indicate faults with the installation or appliance.

Combustion testing must be carried out with all covers in place. The flue gas is sampled in the flue, within 1 meter of the heater. The values of CO₂ should be between 5.7% to 8.0% for natural gas and 6.8% to 9.2% for LPG dependant upon model. The CO will be up to 80 ppm (0.008%) dry, air free dependant upon model. Temperature rise of the flue gases above ambient should be approximately 130° C to 160° C. Seal test hole in flue after testing.

10.2.4 Pressure Switch

The pressure switch is factory pre-set for each model and is not adjustable.

10.2.5 Turning Off the Heater

Set the external controls to the "OFF" position and the main burner will stop.

The fan will run until it is stopped automatically by the fan thermostat.

Do not use Electrical Isolator for control of heater. Electrical Isolator will switch off the fan. Heat exchanger could be damaged. Warranty will not cover damage to the heat exchanger if operated improperly.

10.2.6 External Controls

External Controls may include time switch, room thermostat and frost thermostat. Operate each control to ensure that they function correctly. Set the time switch (if fitted) and room thermostat to the users' requirements.

10.3 Complete the Commissioning

Ensure that all covers are fitted correctly and all test points are properly sealed.

10.3.1 Instruction to the User

Explain the controls of the heater to the user including how to turn it on and off, using the controls fitted on site.

Give this manual to the user.

Ensure that the user is shown and understands the importance of maintaining clearances to combustibles and the user instructions on Page 18, Section 11 through Page 19, Section 11.5 and all warnings defined in this manual.

SECTION 11: USER INSTRUCTIONS

11.1 User Instructions

The CTCU heaters are fully automatic and operate from the external controls fitted on site.

The only user controls at the heater are the:

- Burner Lockout
- Reset Button See Page 18, Section 11.3.3
- Limit Thermostat Reset See Page 18, Section 11.3.2

⚠ WARNING

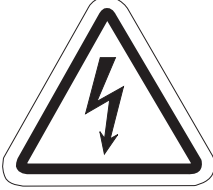

Electrical Shock Hazard

Disconnect electrical power before servicing.

Failure to follow these instructions can result in death or electrical shock.

11.2 Heater Operation

When the heater has been switched on by the remote controls installed on site, the main burner will automatically turn on.

The burner control box will control the safe ignition of the flame.

All heaters require a constant gas and electricity supply which must not be interrupted during the normal operation of this heater.

Figure 11: Heater Operating Sequence

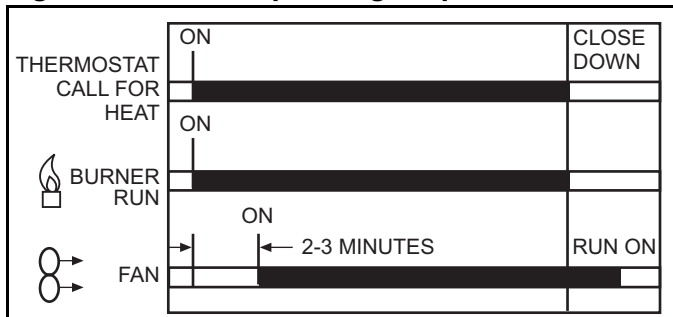

11.3 Common User Controls

11.3.1 Fan Thermostat

The fan thermostat is located inside the access door at the top of the heater. See Page 28, Section 15.3. This control ensures the heater does not blow cold air in the normal heating cycle.

11.3.2 Limit Thermostat

The limit thermostat is located inside the access door of the heater. See Page 28, Section 15.3. This control protects the heat exchanger against overheating.

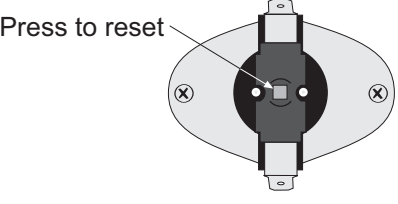

These are hand reset devices to give further protection against fan failure.

NOTE: To reset, the heat exchanger must be cool.

Description	Part Number
Limit Thermostat	90412100

⚠ WARNING



Explosion Hazard

If control locks out, do not make more than 3 attempts to restart the heater.

Dangerous gas mixtures can build up.

The fault must be traced and repaired by a registered installer or service engineer.

Failure to follow these instructions can result in death, injury or property damage.

11.3.3 Burner Lockout Reset Button

The red warning light on the back of the heater will illuminate when the control has gone to lockout. This may be caused by flame failure. Press the reset button on the back of the heater (See Page 5, Section 4.1) or the remote reset if installed on site.

11.4 Lighting Instructions

11.4.1 To Turn On Heater

1. Ensure that the electrical and gas supplies to the heater are on. Check that the on site controls are "ON".

NOTE: The thermostat setting must be above the ambient temperature for the heater to operate.

2. The automatic firing sequence will begin as described on Page 16, Figure 9. The heater will now operate automatically under the control of the on site controls. Following long shut down periods, the control may go to lockout. See Page 18, Section 11.3.3.

11.4.2 To Turn the Heater Off

Set the installed remote controls to the "OFF" position.

The burner will turn off immediately.

The fan will continue to run for a few minutes.

To restart, turn the control used above to "ON".

11.5 Simple Fault Finding

Some possible reasons for the heater not operating are:

1. Gas supply not turned "ON".
2. Electricity supply not turned "ON".
3. The time and/or temperature controls are not "ON".
4. The limit thermostat may have operated. This may be caused by an interruption of the electrical supply or failure of the distribution fan.

If the limit thermostat persistently operates, there is a fault which must be investigated by a contractor qualified in the installation and service of gas-fired heating equipment.

11.5.1 Simple Fault Finding (Burner Faults)

If the burner fails to ignite for any reason, it will go to lockout. This will be indicated by the red light on the back of the heater or at the remote indicator (if fitted).

1. Press in and release the lockout reset button. If a remote reset is not fitted, a reset button is on the back of the heater.

See Page 5, Section 4.1.

Lockout should not occur during normal operation of the heater and indicates there is a fault condition which must be corrected.

FOR YOUR SAFETY

If you smell gas:

1. Open windows.
2. **DO NOT** try to light any appliance.
3. **DO NOT** use electrical switches.
4. **DO NOT** use any telephone in your building.
5. Leave the building.
6. Immediately call your local gas supplier after leaving the building. Follow the gas supplier's instructions.
7. If you cannot reach your gas supplier, call the Fire Department.

WARNING



Fire Hazard

Do not store or use petrol or other flammable vapours and liquids in the vicinity of this or any other appliance.

Some objects will catch fire or explode when placed close to heater.

Failure to follow these instructions can result in death, injury or property damage.

SECTION 12: SERVICING

12.1 Servicing Instructions

After commissioning, the heater will require maintenance to be carried out annually. If the heater is used in a dirty or dusty area, more frequent maintenance may be necessary.

Installation Code and Annual Inspections: All installations and service of ROBERTS GORDON® products must be performed by a contractor qualified in the installation and service of gas-fired heating equipment and conform to all requirements set forth in the ROBERTS GORDON® manuals and all applicable governmental authorities pertaining to the installation, service and operation of the equipment. To help facilitate optimum performance and safety, Roberts-Gordon recommends that a qualified contractor annually inspect your ROBERTS GORDON® products and perform service where necessary, using only ROBERTS GORDON® replacement parts.

<p>Cut Hazard</p> <p>Turn off gas and electrical supply before maintenance.</p> <p>Fan can start automatically at any time.</p> <p>Failure to follow these instructions can result in severe injury or product damage.</p>

NOTE 1: After any maintenance or repair work, always test fire the heater in accordance with the commissioning instructions on *Page 15, Section 10 through Page 17, Section 10.3.1* to ensure all safety systems are in working order before leaving the heater to operate. Minor faults may be traced by using the troubleshooting charts on *Page 22, Section 14 through Page 25, Section 14.5*.

NOTE 2: Check all gas pipes and pipe joints to ensure there are no cracks or gas leaks. Any cracks in the pipes or pipe joints must be repaired.

NOTE 3: Inspect all suspended components and hardware. Insure that they are in good condition, properly tightened, and corrosion free.

12.2 Burner Maintenance

1. Open the door and remove the burner compartment cover. *See Page 27, Section 15.2.*

2. Clean any deposits from the main burner which may have formed in the injectors or venturi of the burner. *See Page 27, Section 15.2.*
3. Remove the ignition electrode and flame probe. Check condition of ignition electrode and flame probe. Clean off any deposits which may have been formed, check condition of ceramic insulators. Replace as necessary.

12.3 Fan/Motor Assembly Maintenance

The main fan bearings are permanently sealed and do not need lubrication. Before cleaning, turn off gas and electrical supply. Remove the fan and use a small brush or duster to clean the fan blades from each side. Replace fan when done.

12.4 Heat Exchanger Maintenance

The heat exchanger will remain clean unless a problem has developed with combustion. Inspect the heat exchanger. Look for signs of overheating at the front tubes which may indicate burner over firing or persistently low air flows.

12.5 Gas Control Valve Maintenance

No regular maintenance is required on this device. To change gas control valves, *See Page 26, Step 15.1 and Page 30, Section 15.5.*

Do not repair or disassemble on site.

Replace faulty gas valves with genuine ROBERTS GORDON® replacement parts.

12.6 Flue Fan

The flue fan should not require maintenance. However, if the air pressure switch is causing burner lockout, then remove the flue fan from the vent box by unscrewing the three screws at the mounting plate. Remove the four screws attaching the mounting plate to the fan inlet (*See Page 29, Section 15.4*). Ensure that the fan is free to run and that the fan wheel is clean.

SECTION 13: CONVERSION BETWEEN GASES

13.1 General

Conversion between gases will require a change of burner injectors and the gas valve re-commissioning to the new conditions.

13.2 Burner Conversion

Conversion of the burner assembly from one gas to the other is the same for all types of heaters.

1. Remove the burner compartment cover as shown on *Page 27, Section 15.2*.
2. Remove the 4 screws holding the manifold and pull out the manifold.
3. Remove inshot burners by rotating them and sliding out the bracket.
4. Remove the main burner injectors.
5. Replace with the injectors for the new gas ensuring a gas tight seal.
6. Refit all components in reverse order.

13.3 Gas Valves

All gas valves used on the CTCU have pressure regulators that may be set to operate on natural gas or LPG.

Conversion is carried out by re-setting the burner pressure to the value in the data table during commissioning. See *Page 6, Section 4.3*.

Ensure that the gas inlet pressure to the heater is correct for the new gas, and that the gas supply has been purged of the old gas.

SECTION 14: TROUBLESHOOTING

14.1 General

⚠ WARNING		
		
Explosion Hazard		
<p>Installation must be done by a registered installer/contractor qualified in the installation and service of gas-fired heating equipment or your gas supplier.</p> <p>Failure to follow these instructions can result in death, injury or property damage.</p>		

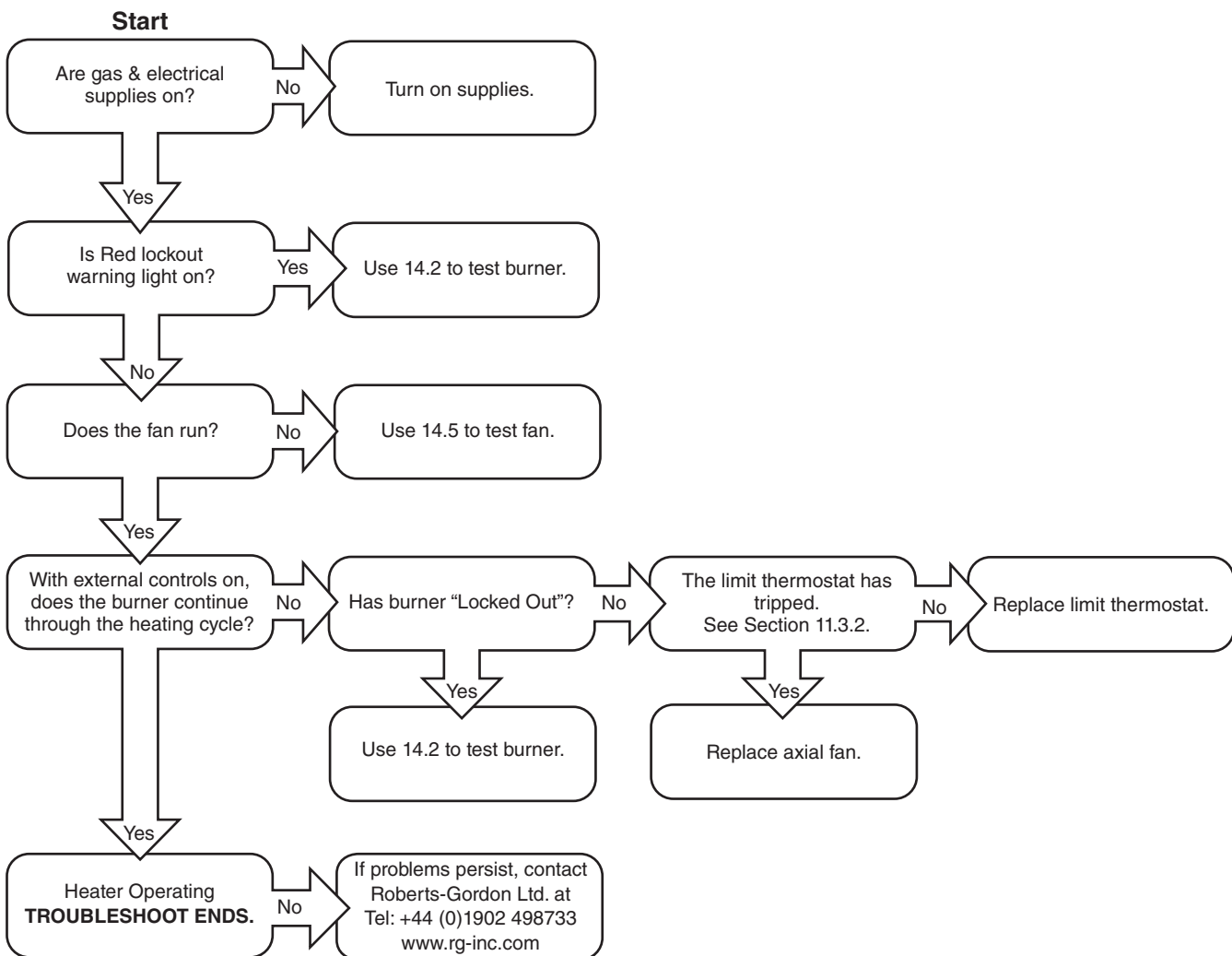

For your safety and optimum heater performance, use only ROBERTS GORDON® replacement parts. Conduct Commissioning procedure as shown on Page 15, Section 10.

14.2 Troubleshooting For Automatic Ignition Burner Systems

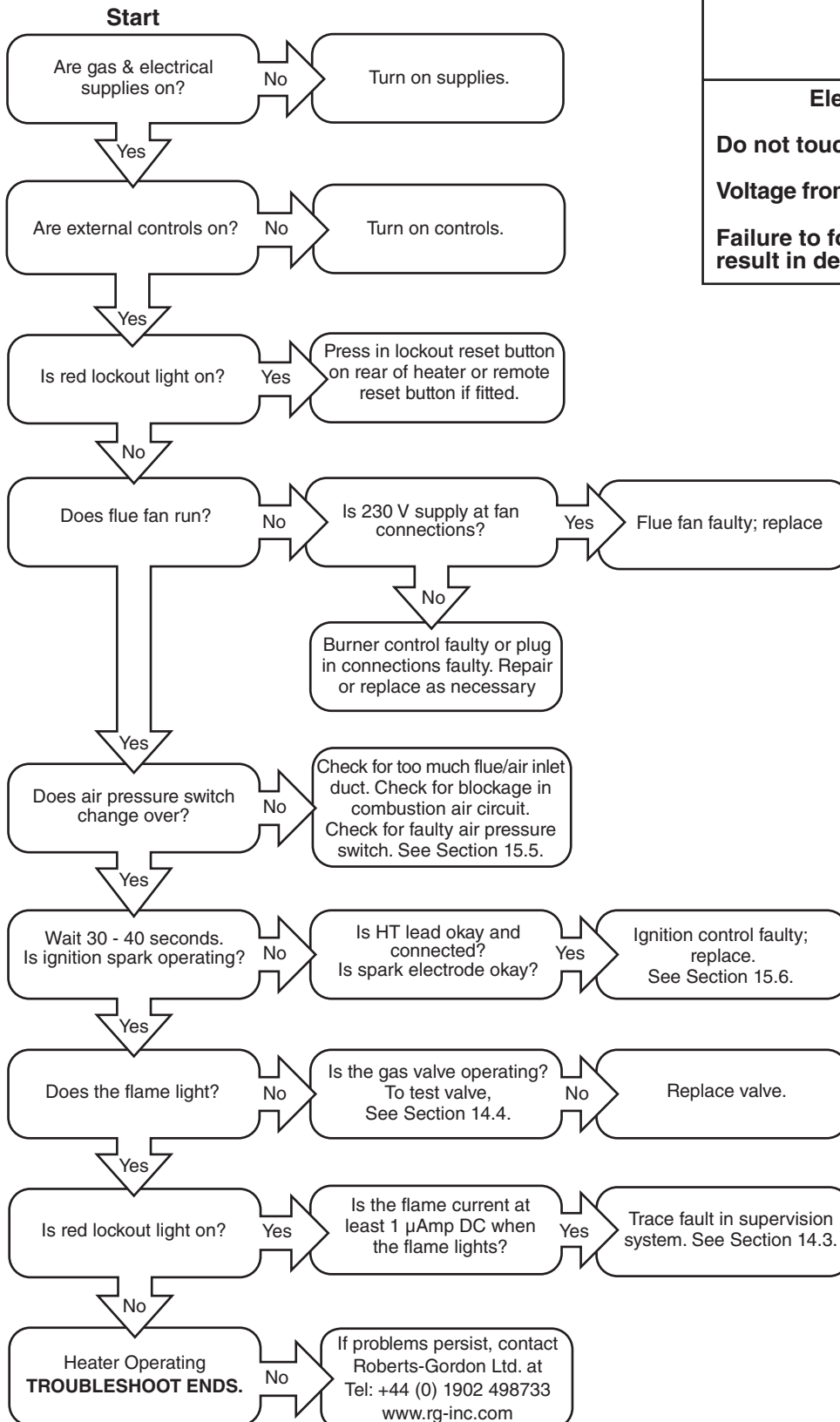
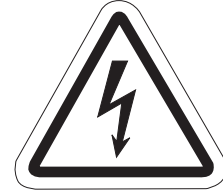
**⚠ WARNING****Electrical Shock Hazard**

Do not touch ignition components.

Voltage from ignition components is high.

Failure to follow these instructions can result in death or electrical shock.

For your safety and optimum heater performance, use only ROBERTS GORDON® replacement parts. **Conduct Commissioning procedure as shown on Page 15, Section 10.**

14.3 Troubleshooting for Flame Supervision System

To measure flame current, connect a 0 - 50 μ A DC meter in series with the flame probe. If the meter reads negative values, then reverse the test leads.

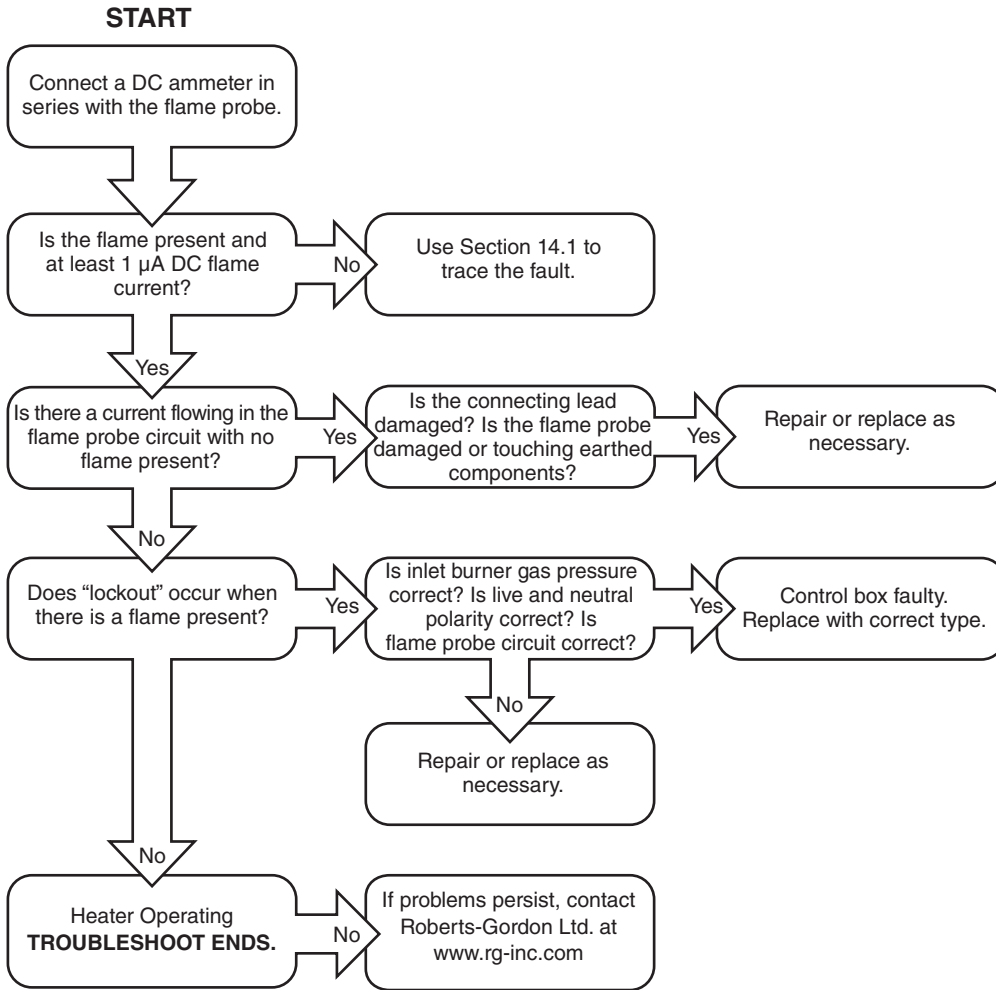

NOTE: Minimum flame probe current 1 μ A DC. Typical flame probe current 3-5 μ A DC.

14.4 Troubleshooting for Solenoid Valves

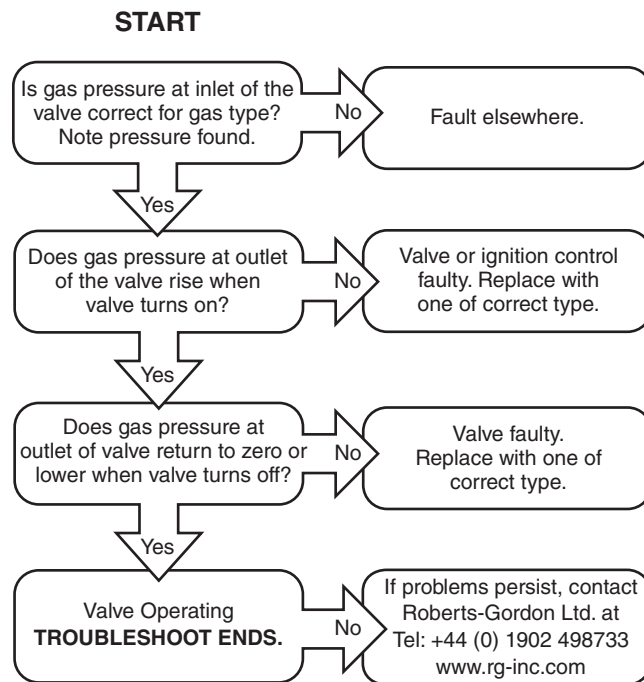

14.5 Troubleshooting for Main Fan

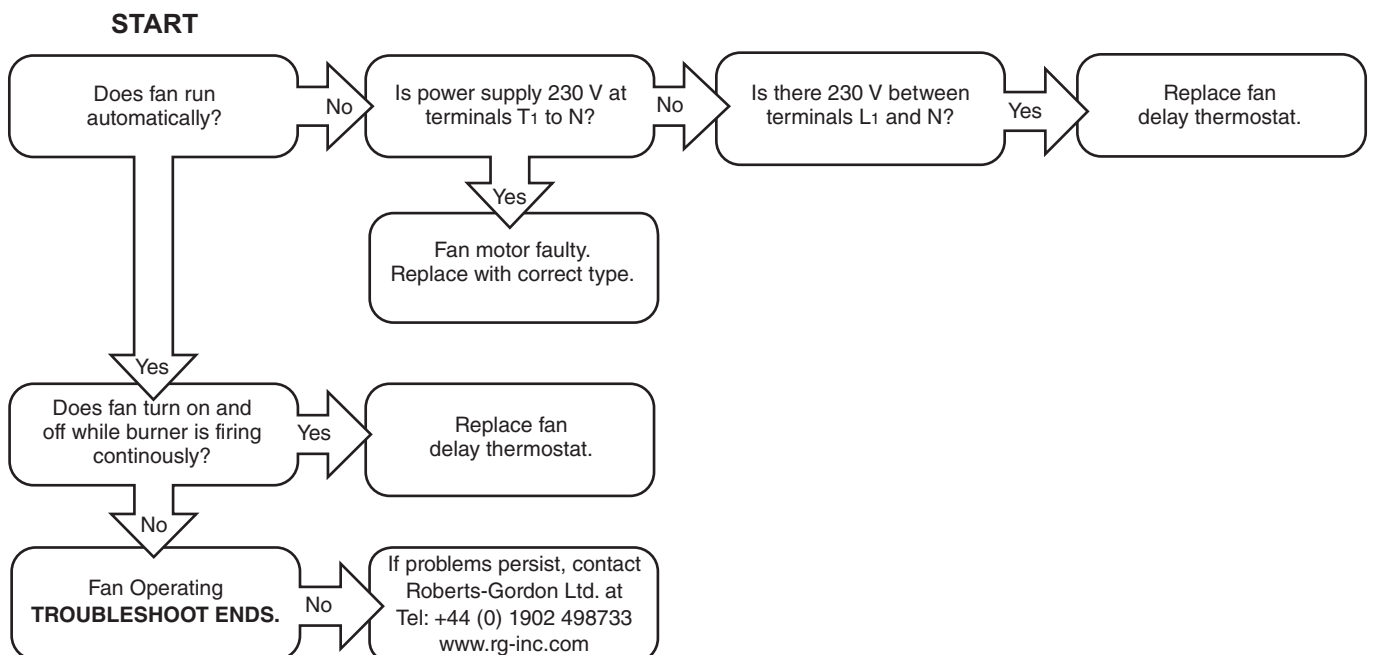

For your safety and optimum heater performance, use only genuine ROBERTS GORDON® replacement parts.

Conduct Commissioning procedure as shown on Page 15, Section 10.

SECTION 15: REMOVAL AND REPLACEMENT PARTS

See warnings and notes on *Page 20, Section 12* before removing or replacing parts.

Burner Components

All serviceable burner parts are accessed by the door on the side of the heater. Remove the four sheetmetal screws.

15.1 Gas Valve

Remove the gas supply pipe at the heater inlet.

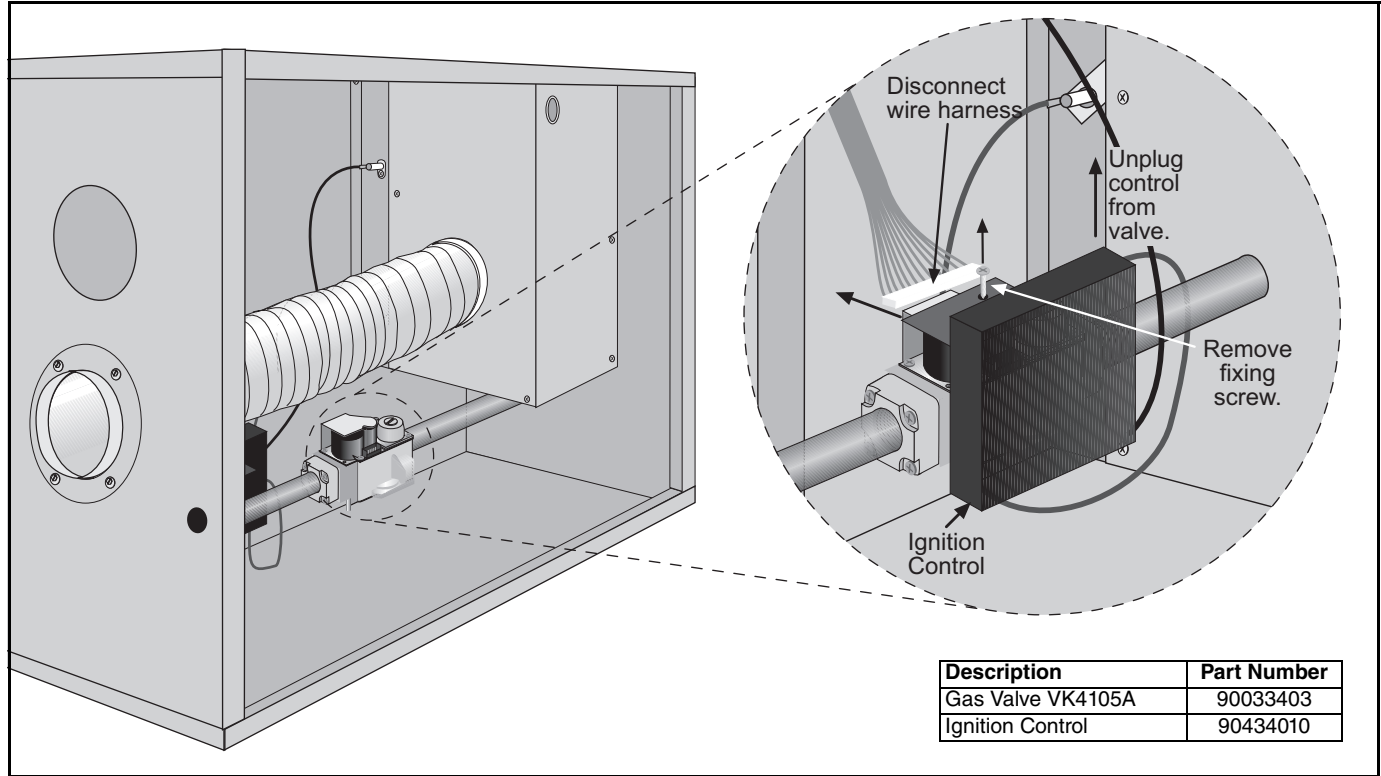

Replace in reverse order. Verify that the gas flow direction of the valve is correct. Use a minimum amount of gas seal on the thread joint. Check that all the joints are leak free. Reset gas valve. See *Page 17, Section 10.2.2*.

IT IS IMPORTANT THAT ONLY THE CORRECT GAS VALVE IS USED WHEN REPLACING THESE CONTROLS.

15.2 Burner Compartment

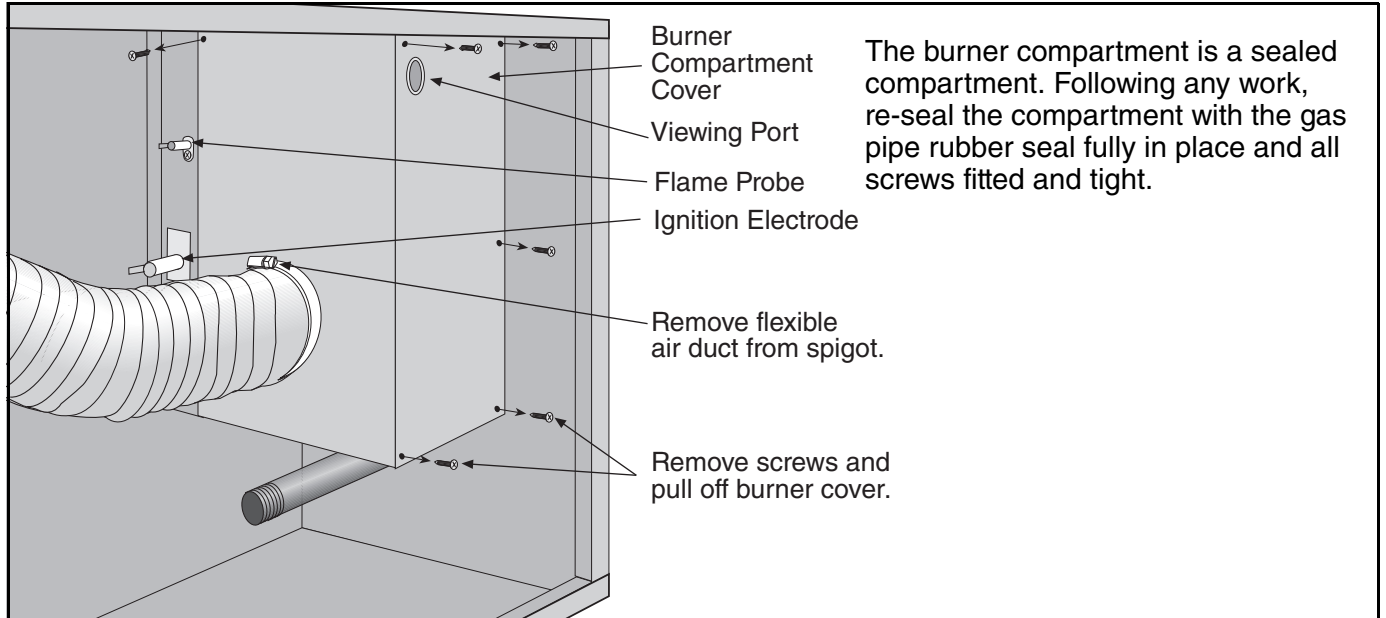

15.2.1 Burner Injectors

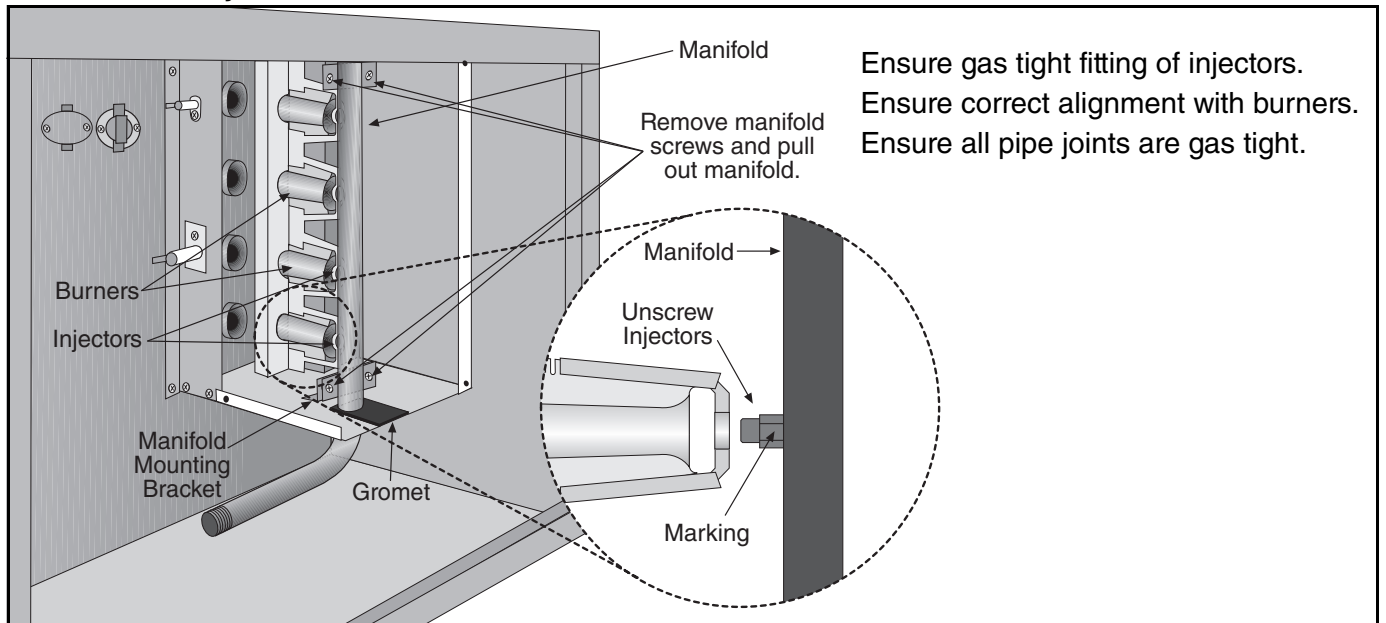

MODEL	CTCU-7	CTCU-11	CTCU-15	CTCU-22	CTCU-27	CTCU-32
Injector Quantity	2	3	4	5	6	7
Natural Gas (G20)						
Injector size mm Ø	1.78	1.85	1.85	2.06	2.057	2.057
in Ø	0.070	0.073	0.073	0.081	0.081	0.081
Marking	50	49	49	46	46	46
RG P/N	91930050	91930049	91930049	91930046	91930046	91930046
Natural Gas (G25)						
Injector size mm Ø	1.99	2.06	2.06	2.26	2.261	2.261
in Ø	0.0785	0.081	0.081	0.089	0.089	0.089
Marking	47	46	46	43	43	43
RG P/N	91930047	91930046	91930046	91930043	91930043	91930043
LPG Propane (G31) and LPG Butane (G30)						
Injector size mm Ø	1.18	1.18	1.18	1.25	1.25	1.25
in Ø	0.0465	0.0465	0.0465	0.049	0.049	0.049
Marking	56	56	56	1.25	1.25	1.25
RG P/N	91930056	91930056	91930056	91930125	91930125	91930125

15.3 Ignition Electrode and Flame Probe

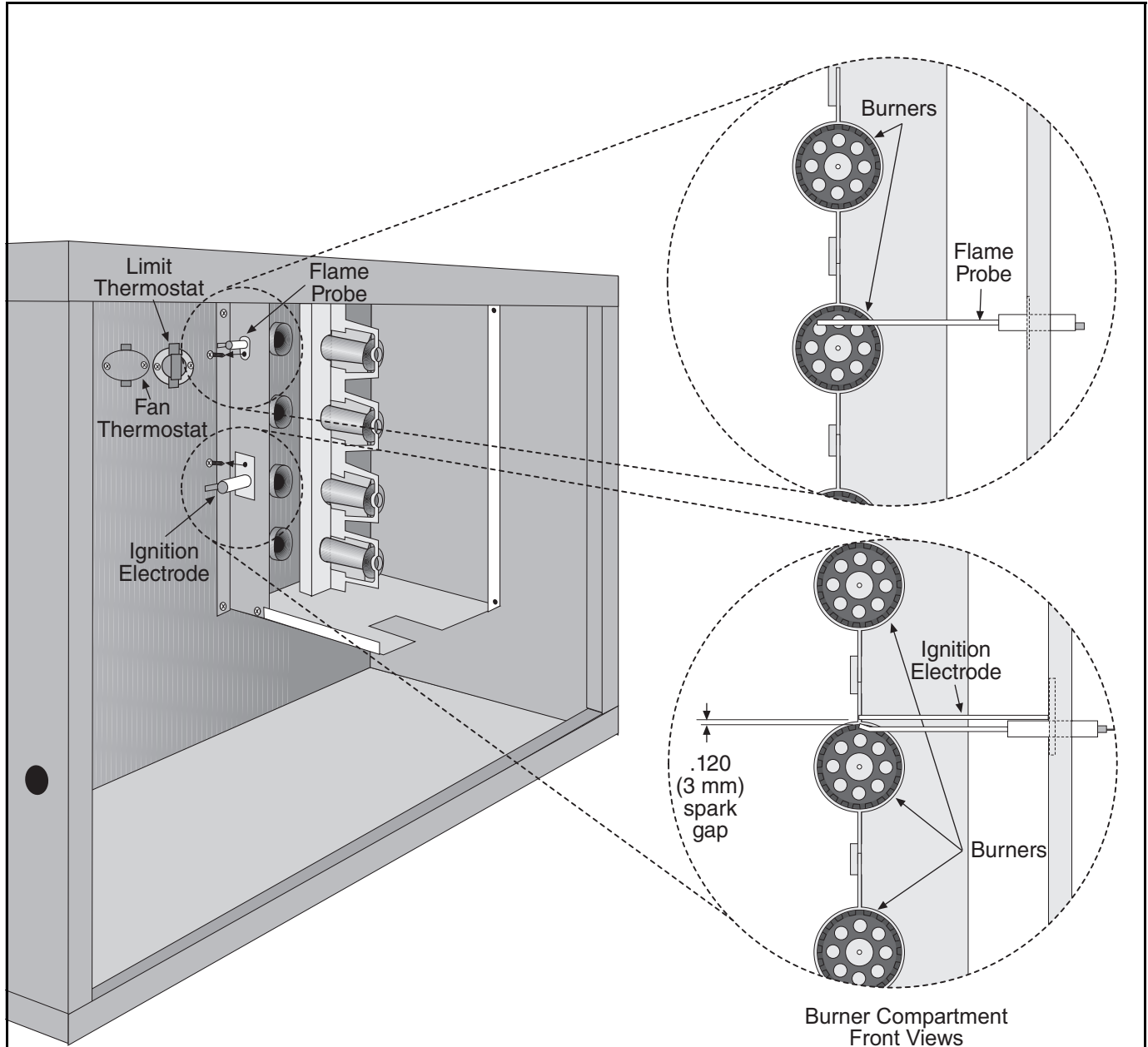

To replace the ignition electrode or flame probe, remove the electrical lead and screw. Pull out from mounting. Refit in reverse ensuring that the gap to burner is as shown in the front view of the burner compartment.

Description	Part Number
Spark Electrode	90427411
Automatic Ignition Flame Probe	90439300
Burners	92000002
Fan Thermostat	90412102
Limit Thermostat	90412100

15.4 Flue Fan Vertical Installation

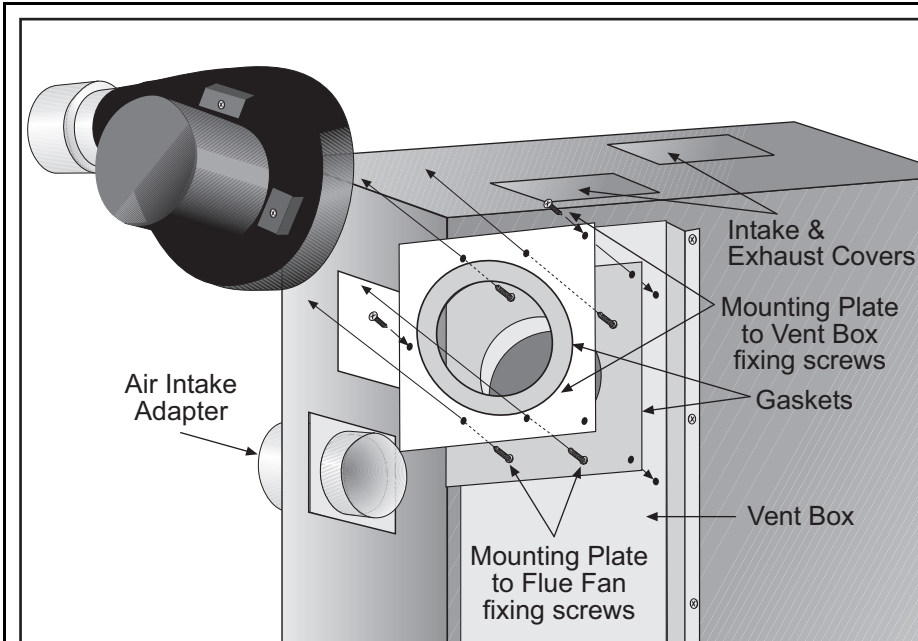

To remove the fan, remove 3 screws securing the fan and mounting plate to the vent box.

To remove the fan from the mounting plate, remove the 4 screws.

Refit in reverse order.

To change the flue and air intake orientation from back to top, remove the fan and mounting plate as above.

Remove intake and exhaust covers from top of the heater.

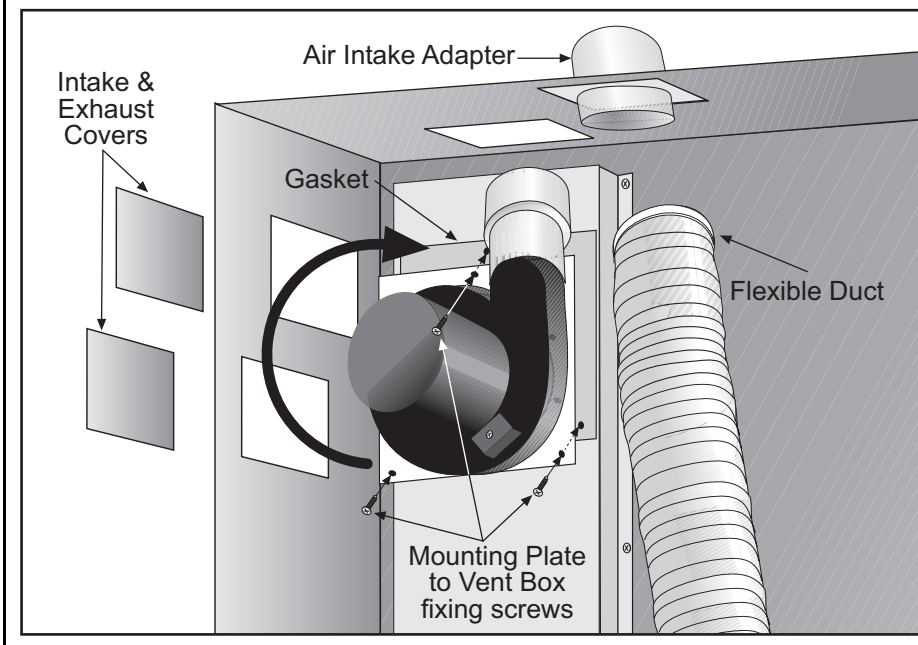

Rotate the fan, mounting plate and gasket clockwise until the flue adapter lines up with the top hole. Secure with 3 screws.

Remove the flexible duct from the air intake adapter on the back.

Remove the air intake adapter from the back of the heater and install in the appropriate hole on top. Reconnect the flexible duct.

Install intake and exhaust covers over the back holes.

Ensure sealed joints. Ensure mounting plate orifice is clear and not obstructed.

MODEL		CTCU-7	CTCU-11	CTCU-15	CTCU-22	CTCU-27	CTCU-32
Flue Fan		Fasco 7021-11767	Fasco 7021-11768	Fasco 7021-11769	Torin S6818	Sit Controls P1210838	Sit Controls P1210838
RG P/N		90710470	90710470	90710470	90710460	90710460	90710460
Air Plate	mm Ø	35	44	57	64	109.2	109.2
	in Ø	1.38	1.75	2.25	2.50	4.3	4.3
RG P/N		1111210	11112210	11113210	11114210	11115210	11115210

IT IS IMPORTANT THAT ONLY THE CORRECT FLUE FAN SPECIFIED FOR EACH MODEL TYPE IS USED WHEN REPLACING THESE ITEMS.

Carry out a commission after working on or changing a flue fan. See Page 18, Section 11.

15.5 Pressure Switch

Pull off 3 way connector. Spring open plastic clips of mounting cradle. Replace with correct type of pressure switch for model. The pressure switches are colour coded for each pressure setting.

⚠
WARNING



Carbon Monoxide Hazard

Use correct pressure switch specified for each model.

Use of incorrect pressure switch could cause unsafe condition.

Failure to follow these instructions can result in death or serious injury.

Carry out a commission after working on or changing a pressure switch. See Page 15, Section 10.

Pressure Switch	CTCU-7	CTCU-11	CTCU-15	CTCU-22	CTCU-27	CTCU-32
RG P/N	90439812	90439812	90439812	90439803	90439803	90439803
Colour Code	orange	orange	orange	grey	grey	grey
Set Point mbar	0.45	0.45	0.45	1.02	1.02	1.02
in wc	0.18	0.18	0.18	0.41	.041	.041

15.6 Ignition Control

The control plugs onto the gas valve. Pull out 12 pin electrical connection. Pull out ignition cable and flame probe cable noting their positions

Release screw securing control to gas valve.

Refit in reverse. Ensure correct location of ignition and flame probe cables. Ensure that the earth connection is made directly to the earth point on the gas valve.

15.7 CTCUA Axial Fan/Guard/Motor Assembly

The axial fan unit for the CTCUA heater is supplied completely assembled and balanced.

15.7.1 Fan Removal and Replacement

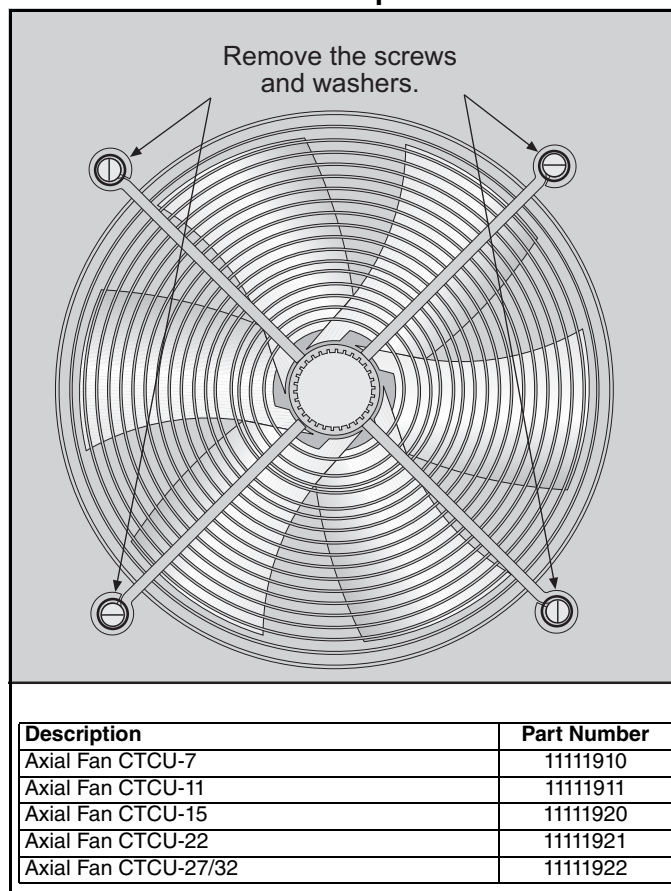

15.7.2 To Replace the Fan Assembly

To replace the fan assembly, reverse the procedure shown above. Fit rubber washers to the guard mountings to reduce vibration.

- Check that the fan blades are free to rotate before turning on the power to the fan.
- Strictly comply with the colour code of the fan wires to ensure correct operation. See Page 14, Section 9.3 wiring diagram.
- Use only genuine ROBERTS GORDON® replacement parts.

15.8 Fan and Limit Thermostats

15.8.1 Removal and Replacement

1. Pull off the electrical connections to the thermostat
2. Unscrew the two screws securing the thermostat
3. Fit a new thermostat with two screws ensuring that the correct temperature setting and type are selected.
See Page 6, Section 4.3.
4. Reconnect the electrical connections and test operation.

Attach this information to the wall near the ROBERTS GORDON® heater



Read the installation, Commissioning, Operation and Service Manual thoroughly before installation, operation or service.

OPERATING INSTRUCTIONS

⚠ WARNING

1. STOP! Read all safety instructions on this information sheet.
 2. Open the manual gas valve in the heater supply line.
 3. Turn on electric power to the heater.
 4. Set the thermostat to desired setting (above ambient temperature).
The automatic starting sequence begins.
- NOTE:** Following long shutdown periods, the burner control may go to 'LOCKOUT' during the start sequence. Push the reset button to recommence firing. Contact service department if 'LOCKOUT' continues (see manual for details).



TO TURN OFF THE HEATER

Fire Hazard

1. Turn the thermostat/time switch to 'OFF'. The burner will turn 'OFF' immediately, but fans will continue to cool heat exchanger until the fan thermostat switches off.

Some objects can catch fire or explode when placed close to heater.

IF THE HEATER WILL NOT OPERATE, TO ENSURE YOUR SAFETY, FOLLOW THESE INSTRUCTIONS TO SHUT DOWN YOUR HEATER

Keep all flammable objects, liquids and vapors the required clearances to combustibles away from heater.

1. Set the thermostat to off or the lowest setting.
2. Turn off electric power to the heater.
3. Turn off the manual gas valve in the heater supply line.
4. Call your registered installer/contractor qualified in the installation and service of gas-fired heating equipment.

Failure to follow these instructions can result in death, injury or property damage.

Installation Clearances

Clearances to Combustibles

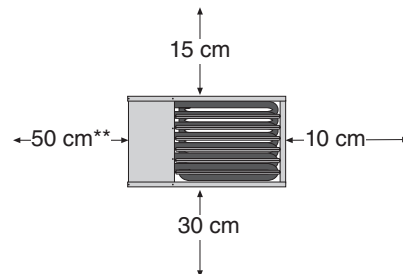
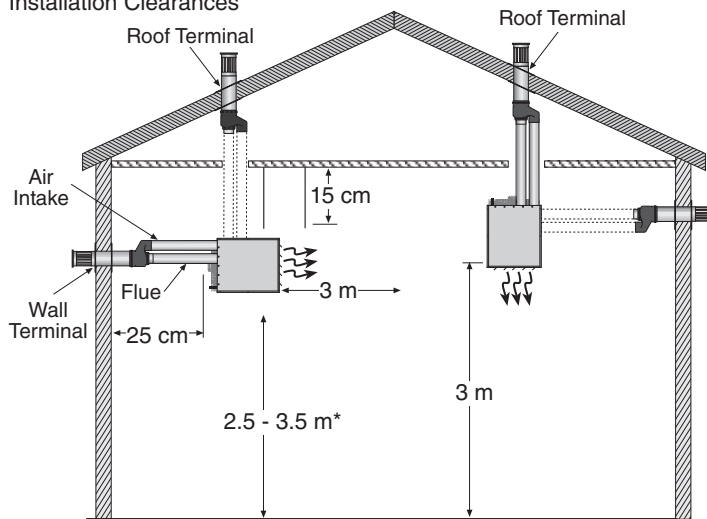

*Heaters may be mounted at a higher level if destratification fans are installed.

**80 cm is necessary to service heater

Roberts-Gordon, LLC
1250 William Street
P.O. Box 44
Buffalo, NY 14240-0044 USA
Telephone: 716.852.4400
Fax: 716.852.0854
Toll Free: 800.828.7450

Roberts-Gordon Europe Limited
Oxford Street
Bilston, West Midlands WV14 7EG UK
Telephone: +44(0) 1902 494425
Fax: +44(0) 1902 403200

Service Telephone: +44(0) 1902 498733
Service Fax: +44(0) 1902 401464
E-mail: uksales@rg-inc.com
E-mail: export@rg-inc.com

Installation Code and Annual Inspections: All installations and service of ROBERTS GORDON® products must be performed by a contractor qualified in the installation and service of products sold and supplied by Roberts-Gordon and conform to all requirements set forth in the ROBERTS GORDON® manuals and all applicable governmental authorities pertaining to the installation, service and operation of the equipment. To help facilitate optimum performance and safety, Roberts-Gordon recommends that a qualified contractor annually inspect your ROBERTS GORDON® products and perform service where necessary, using only ROBERTS GORDON® replacement parts.

Further Information: Applications, engineering and detailed guidance on systems design, installation and product performance is available through ROBERTS GORDON® representatives. Please contact us for any further information you may require, including the Installation, Operation and Service Manual.

This product is not for residential use.
This document is intended to assist licensed professionals in the exercise of their professional judgement.

© 2006 Roberts-Gordon, LLC All rights reserved. No part of this work covered by the copyrights herein may be reproduced or copied in any form or by any means – graphic, electronic, or mechanical, including photocopying, recording, taping, or information storage and retrieval systems – without written permission of Roberts-Gordon, LLC.

www.rg-inc.com

Printed in U.S.A.